

COMPUTHERM Q7RF (RX)

**Wireless receiver unit
(radio-frequency) for *COMPUTHERM*
room thermostats**



Operating Instructions

A GENERAL DESCRIPTION OF THE RECEIVING UNIT

Room thermostat receiver **COMPUTHERM Q7RF (RX)** is suitable to operate together with wireless room thermostats **COMPUTHERM Q3RF**, **COMPUTHERM Q5RF**, **COMPUTHERM Q7RF** and **COMPUTHERM Q8RF**. The **COMPUTHERM Q7RF (RX)** type switched-mode room thermostat receiver controlled by a wireless **COMPUTHERM** room thermostat is suitable to regulate the overwhelming majority of boilers and air conditioners. It can be easily connected to any gas boiler having a two-wire thermostat connection point and to any air conditioning apparatus or electrical apparatus, regardless of whether they have a 24 V or 230 V control circuit. The receiving unit controls the connected gas boiler or another electric device according to signals coming from the room thermostat switch.

If you want to make your gas convector controllable with a room thermostat using **COMPUTHERM KonvekPRO**

and a **COMPUTHERM** wireless room thermostat and you wish to control several gas heaters with a single room thermostat, you can accomplish this task by means of a **COMPUTHERM Q7RF (RX)** receiver unit. A single **COMPUTHERM** wireless room thermostat can be synchronized with several **COMPUTHERM Q7RF (RX)** receiver units at the same time, and this make simultaneous control of several gas convectors feasible (for more details please refer to Chapter 1).

1. INSTALLATION AND CONNECTION OF THE RECEIVER UNIT

WARNING! The device must be installed and connected by a qualified professional. Before installing, make sure that that neither the thermostat nor the device to be controlled is connected to the 230 V mains voltage. Modifying the receiver unit can cause electric shock or product failure.

The **COMPUTHERM Q7RF (RX)** receiver unit should be mounted on the wall in a place protected against mois-

ture, dust, chemicals and heat, in the vicinity of the boiler. When choosing the location of the receiving unit you should remember that bulky metal objects (e.g. a boiler, buffer tank, etc.) and metal building structures may have an adverse effect on propagation of radio waves. If it is possible, in order to ensure trouble-free RF connection, we recommend that you install the receiving unit at a height of 1.5 to 2 m and at a distance of 1 to 2 m from the boiler or other bulky metal constructions. We recommend that you check reliability of RF connection at the place selected before installing the receiving unit.

ATTENTION! Do not install the receiver unit under the housing of the boiler or near hot pipes because it may damage the parts of the device or compromise wireless (radio-frequency) connection.

Unscrew the two screws at the bottom of the receiver unit without removing them. Following this, remove the front panel of the receiver unit then fix the back panel to the wall in the vicinity of the boiler with the screws provided.

The marks of the connections are pressed into the plastic above the connection points: **N**, **L**, **1**, **2** and **3**.

230 V mains voltage should be supplied to the receiver unit. This provides the power supply for the device, but this voltage does not appear on the terminals **1** and **2**. We propose to connect the neutral wire of the network to point **N**, while the phase conductor to point **L**. There is no need for grounding as the product is double insulated. We recommend to de-energize the device when heating is continuously not needed (e.g. during summer).

The receiver unit controls the boiler or air conditioner through a potential-free alternating relay whose connection points are: **1** (NO), **2** (COM) and **3** (NC). Connect the two connection points of the heating or cooling equipment to be controlled to terminals **1** (NO) and **2** (COM), i.e. to the normally open terminals of the relay as shown in the figure.

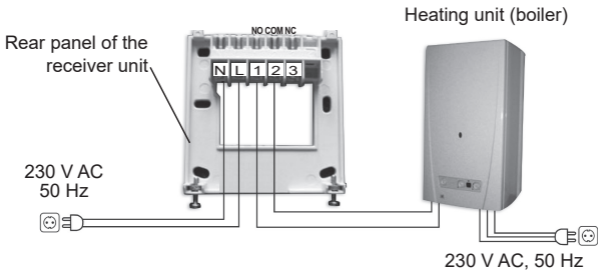

If you would like to operate an old boiler or any other device that has no connection points for thermostats, then the **1** (NO) and **2** (COM) connection points of the thermostat should be connected to the mains cable of the device, similarly as a switch would be connected, as shown in the figure below.

Rear panel of
the receiver unit

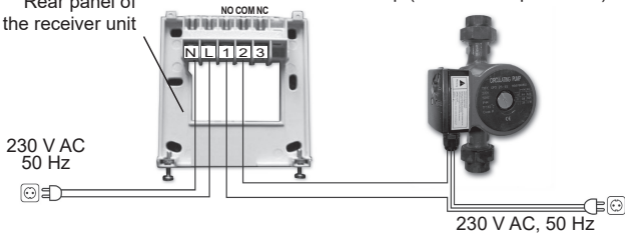

If you want to control several gas convectors by using a single room thermostat then you need a **COMPUTHERM** wireless room thermostat (it already comprises a receiving unit), and as many **COMPUTHERM KonvekPRO** gas convector controllers as the number of gas convectors to be controlled and one less **COMPUTHERM Q7RF (RX)** supplementary receiving units. The figure below shows control of two gas convectors with a single wireless room thermostat. In case of more than two gas convectors a similar arrangement

can be implemented by additional receiving units and **COMPUTHERM KonvekPRO** gas convector controllers.

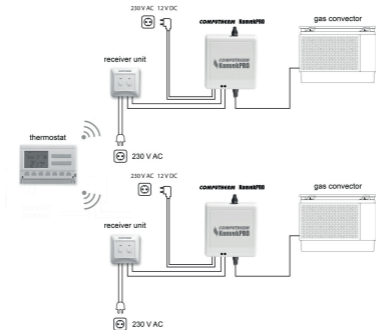

When you are able to establish wired connection between the gas convectors, you can also set up the system by using fewer **COMPUTHERM Q7RF (RX)** receiving units as shown in the figure below.

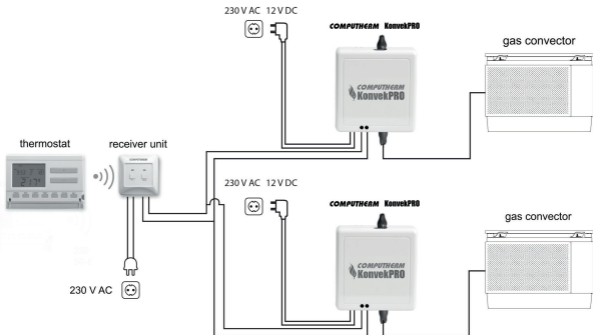

ATTENTION! Always consider the loadability of the receiver unit and follow the manufacturer's instructions of the heating or cooling equipment.

The voltage appearing at terminals **1** and **2** depends only on the system being controlled, therefore the dimensions of the wire are determined by the type of the device to be controlled. The length of the wire is of no significance, the receiver unit may be installed either near the boiler or far away from it, but do not install it under the housing of the boiler.

If the distance between the transmitter and receiver units is too large due to local circumstances and it makes the wireless (radio-frequency) connection unreliable, install the receiver unit nearer to the place of thermostat or use a **COMPUTHERM Q2RF** signal repeater to increase the communication distance.

2. PUTTING THE RECEIVER UNIT INTO OPERATION

Turn on the power supply to the receiver unit. Press the “**M/A**” button of the receiver unit and keep it depressed (for approximately 10 seconds) until the green LED starts flashing. Following this, synchronize the thermostat with the receiver unit(s) according to the instructions for use of your room thermostat. The synchronization was successful if the green LED stops flashing and goes out, so that the receiver unit “learns” the safety code of the transmitter (thermostat). The safety code will not be lost even during a power outage, the device memorizes it automatically.

3. TRANSMISSION DISTANCE INSPECTION

You can check proper functioning of wireless (RF) connection between the wireless (RF) thermostat and the receiver units by following instructions for use provided for the thermostat being used.

4. MANUAL CONTROL OF THE RECEIVER UNIT

Pressing the “**MANUAL**” button separates the thermostat from the receiver unit. In this case, the boiler or air conditioner connected to the receiver unit can only be turned on and off manually, without any temperature inspection. The continuously illuminated green LED indicates “**MANUAL**” mode. Pressing the “**M/A**” button turns on or off the boiler. (The red LED is illuminated when the boiler is turned on). By pressing the “**MANUAL**” button again, the device quits manual control and resumes automatic (thermostat-controlled) operation (the green LED turns off).

FREQUENTLY ASKED QUESTIONS

When you think that your appliance is operating incorrectly or encounter any problem while the appliance is being used then we recommend that you read Frequently Asked Questions (FAQ) available on our website, where we collected the problems and questions that most frequently occur while our appliances are being used, along with the solutions thereto:

<https://www.computherm.info/en/faq>



The vast majority of the problems encountered can be solved easily by using the hints available on our website, without seeking professional help. If you have not found a solution to your problem, please pay a visit to our qualified service.

Warning! The manufacturer does not assume responsibility for any direct or indirect damages and loss of income occurring while the appliance is being used.

PRODUCT INFORMATION DATA SHEET:

- Trademark: **COMPUTHERM**
- Model identifier: **Q7RF (RX)**

TECHNICAL DATA

- | | |
|---|------------------------------------|
| - power supply voltage: | 230 V AC, 50 Hz |
| - power consumption: | 0.01 W |
| - switchable voltage: | max. 30 V DC / 250 V AC |
| - switchable current: | 6 A (2 A inductive load) |
| - protection against environmental impacts: | IP30 |
| - storage temperature: | - 10 °C to +40 °C |
| - operating humidity: | 5% - 90% (without condensation) |
| - dimensions: | 85 x 85x 37 mm (W x H x D) |
| - weight: | 150 g |

The **COMPUTHERM Q7RF (RX)** type thermostat receiver complies with the requirements of directives RED 2014/53/EU and RoHS 2011/65/EU.



Manufacturer: QUANTRAX Ltd.

Fülemüle u. 34., Szeged, H-6726, Hungary

Phone: +36 62 424 133 • Fax: +36 62 424 672

E-mail: iroda@quantrax.hu

Web: www.quantrax.hu • www.computherm.info

Origin:

China

