

COMPUTHERM E800RF

*multizone Wi-Fi thermostat
with touch button controllers*



Operating instructions



COMPUTHERM E Series

TABLE OF CONTENTS

1. A GENERAL DESCRIPTION OF THE THERMOSTAT	5
2. IMPORTANT WARNINGS AND SAFETY RECOMMENDATIONS	8
3. MEANING OF THE LED LIGHTS ON RECEIVER UNIT	9
4. INFORMATION APPEARING ON THE DISPLAY OF THE THERMOSTAT	10
5. FUNCTIONS ACCESSIBLE IN THE PHONE APPLICATION	11
6. LOCATION OF THE THERMOSTAT AND THE RECEIVER UNIT	12
7. CONNECTION AND INSTALLATION OF THE THERMOSTAT AND THE RECEIVER UNIT	13
7.1. Putting the thermostat into operation	13
7.2. Putting the receiver unit into operation	14
7.2.1. Connecting the controlled device to the receiver unit	14
7.2.2. Connecting the receiver unit to the mains	15
7.3. Synchronization of the thermostat and the receiver unit	16
8. SETTING UP THE INTERNET CONTROL	18
8.1. Installing the application	18
8.2. Connecting the thermostat to a Wi-Fi network	19
8.3. Connecting the thermostat to the application	20
8.4. Controlling a thermostat by multiple users	20
9. BASIC OPERATION OF THE THERMOSTAT	21
10. BASIC SETTINGS	21
10.1. Renaming the thermostat assigned to the application	21

10.2. Disabling further connections of the thermostat assigned to the application	22
10.3. Deleting the thermostat assigned to the application	22
10.4. Setting the day and time	22
10.5. Locking operating buttons	23
11. OPERATION-RELATED SETTINGS	23
11.1. Selecting the switching sensitivity (DIF)	25
11.2. Calibration of the temperature sensor (ADJ)	26
11.3. Antifreezing (FRE)	26
11.4. Memorizing ON/OFF status in case of a power failure (PON)	26
11.5. Changing between heating or cooling mode (FUN)	27
11.6. Restoring default setting (FAC)	27
11.7. Delay of receiver unit outputs	27
12. SWITCHING BETWEEN ON AND OFF POSITIONS AND MODES OF THE DEVICE	28
12.1. Manual mode	29
12.2. Programmed auto mode	29
12.2.1. Description of the programmed mode	29
12.2.2. Description of the steps of programming	30
12.2.3. Modifying temperature until the next switch in the program	32
13. PRACTICAL ADVICES	32
14. TECHNICAL DATA	34

1. GENERAL DESCRIPTION OF THE THERMOSTAT

COMPUTHERM E800RF Wi-Fi thermostat is a switching device that can be operated by a smartphone or tablet via Internet, and we especially recommend it for controlling heating or cooling systems. It can be easily connected to any gas boiler having a two-wire thermostat connection point and to any air conditioning apparatus or electrical apparatus, regardless of whether they have a 24 V or 230 V control circuit.

The basic package of the device includes two wireless programmable Wi-Fi thermostats and a receiver. If required, it can be expanded with 6 more **COMPUTHERM E800RF (TX)** Wi-Fi thermostats. The receiver receives the switching signals of the thermostats, controls the boiler or cooling device (load capacity: max. 30 V DC / 250 V AC, 3 A [1 A inductive load]) and gives commands to open/close the heating zone valves (max. 8 zones, load capacity per zone 230 V AC, max: 3 A /1 A inductive/) belonging to the thermostats, as well as to start the pump connected to the common pump output.(load capacity per zone 230 V AC, max: 3 A /3 A inductive/). The zone outputs and the maximum load capacity of the combined pump output is 15 A (4 A inductive load).

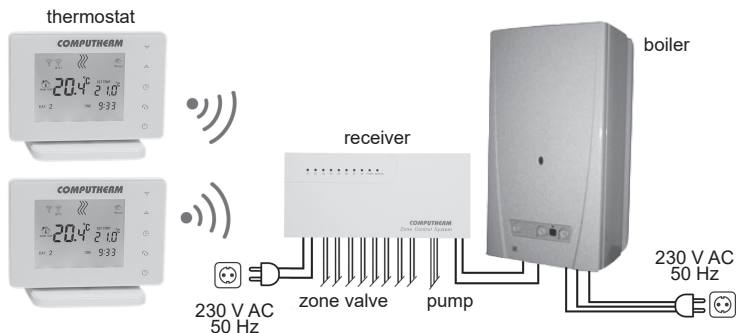

An example of dividing the heating system into zones is shown in the figure below:

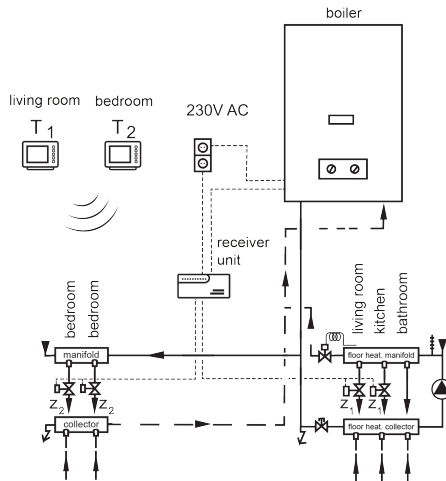

By dividing a heating / cooling system into zones, the various zones can operate either simultaneously or independently of each other. **This way only those rooms are heated at a given time, whose heating is required.** (e.g. the living room and bathroom during the day and the bedroom at night). More than 8 zones can be controlled by using additional **COMPUThERM E80ORF (TX)** thermostats (1 receiver per 8 zones is required). In this case, the potential-free boiler output (**NO-COM**) must be connected in parallel to the boiler and the zone outputs work independently.

There is a wireless (radio frequency) connection between the thermostats and the receiver units, so there is

no need to build a wire between them. The thermostat and their receiver have their own security code, which guarantees the safe operation of the device. See **Chapter 7** for installation, connection and synchronization of the receiver with the thermostats.

The thermostat does not transmit continuously, but repeats its current switching command every 6 minutes, and heating/cooling control is provided even after a power failure, if this option is selected in the settings (see **Chapter 11**).

The range of the transmitter installed in the thermostats in open field is approx. 250 m. This distance may be significantly reduced inside a building, especially if a metal structure, reinforced concrete, or adobe wall gets in the way of radio waves.

The portability of the thermostat offers the following advantages:

- no need to lay a cable, which is especially advantageous when old buildings are being modernized,
- the optimal location of the device can be selected during operation,
- it is also advantageous when you intend to locate the thermostat in different rooms in the course of the day (e.g. in the living room during the day but in the bedroom at night).

All thermostats connected to the multi-zone receiver can be easily controlled via both Internet and touch button interface, and its operating conditions can be checked continuously. The device also offers the option of automatic control based on temperature and time. Several thermostats, even installed in different locations, can be registered and controlled in the same user account

A **COMPUTHERM E800RF** thermostats can be used to control:

- gas boilers
- an existing heating/cooling system remotely
- electric water heaters
- solar systems
- certain groups of other electric devices

With the help of the product the heating/cooling system of your flat, house or holiday home can be made controllable from any place and at any time. This product is especially useful when you do not use your flat or house according to a predefined schedule, you leave your home for an uncertain period of time during the heating season or you intend to use your holiday home during the heating season as well.

2. IMPORTANT WARNINGS AND SAFETY RECOMMENDATIONS

- Before starting to use the thermostat, make sure that the Wi-Fi network is reliably accessible at the place where you intend to use the apparatus.
- This device has been designed for indoor use. Do not use it in a humid, dusty or chemically aggressive environment.
- This device is a thermostat that can be controlled via a wireless Wi-Fi network. To prevent jamming, keep it away from such electric equipment which may interfere with wireless communications.
- The manufacturer will assume no responsibility for any possible direct or indirect damages or income losses incurring during the use of the device.
- The device will not work without power supply, but the thermostat is able to memorize settings. In case of power failure (outage) it can resume operation without any external intervention after the power supply is restored, provided that this option has been chosen among settings (see **Chapter 11**). If you intend to use the device in an environment where power outages occur frequently, for safety purposes we propose you to control proper operation of the thermostat regularly.
- **Before actually starting to control the device connected to the thermostat, make sure that the device is perfectly functioning when it is controlled by the thermostat and it can be operated reliably.**
- The software of the thermostat and the telephone application is constantly upgraded and updated. For proper operation please check regularly whether there is any accessible software or telephone application update, and always use their latest version! Due to constant updates it is possible that some functions of

the device and the applications operate and appear in a way other than described in these instructions for use.

- After modifying the desired temperature or any setting on the thermostat by using the touch buttons, the thermostat will send the changed settings to the web server and the receiver after approx. 15 seconds (after the display backlight is turned off).

3. MEANING OF THE LED LIGHTS ON RECEIVER UNIT

The operating status of the receiver unit is indicated by eight red, one orange, one purple and one green LEDs as described below:

- Each of the eight zones has a red LED, whose continuous lighting indicates the switched-on state of the given zone output. The marking of these is: **Z1, Z2, ..., Z8**
- The switched-on state of the shared pump output is indicated by the continuous lighting of the yellow LED marked: **PUMP**.
- The switched-on status of the boiler output is indicated by the continuous lighting of the rightmost blue LED, marked: **BOILER**.
- The continuous lighting of the purple LED inside the receiver, to the left of the spiral antenna, next to the **DELAY** label, indicates the activated status of the output delay function.
- The continuous lighting of the green LED located inside the receiver above the grounding connection point, next to the word **POWER**, indicates that the receiver is switched on.

4. INFORMATION APPEARING ON THE DISPLAY OF THE THERMOSTAT

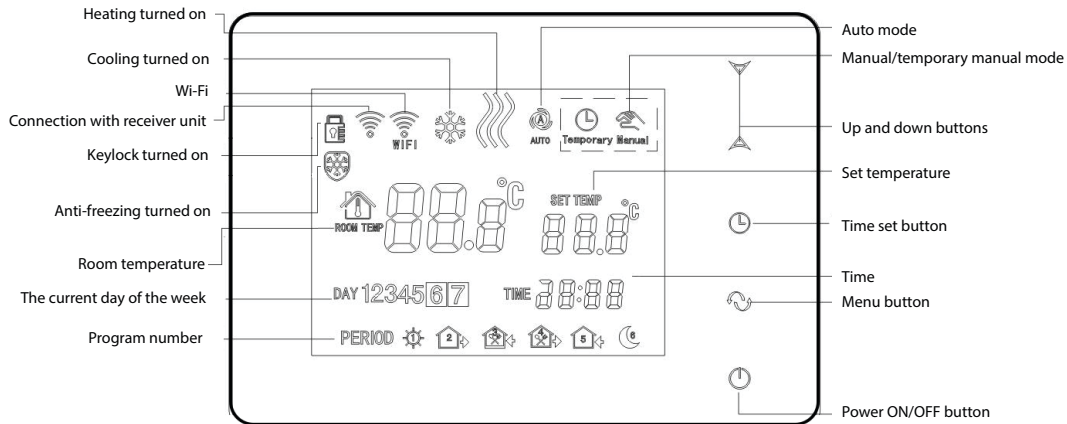

Figure 1.

5. FUNCTIONS ACCESSIBLE IN THE PHONE APPLICATION

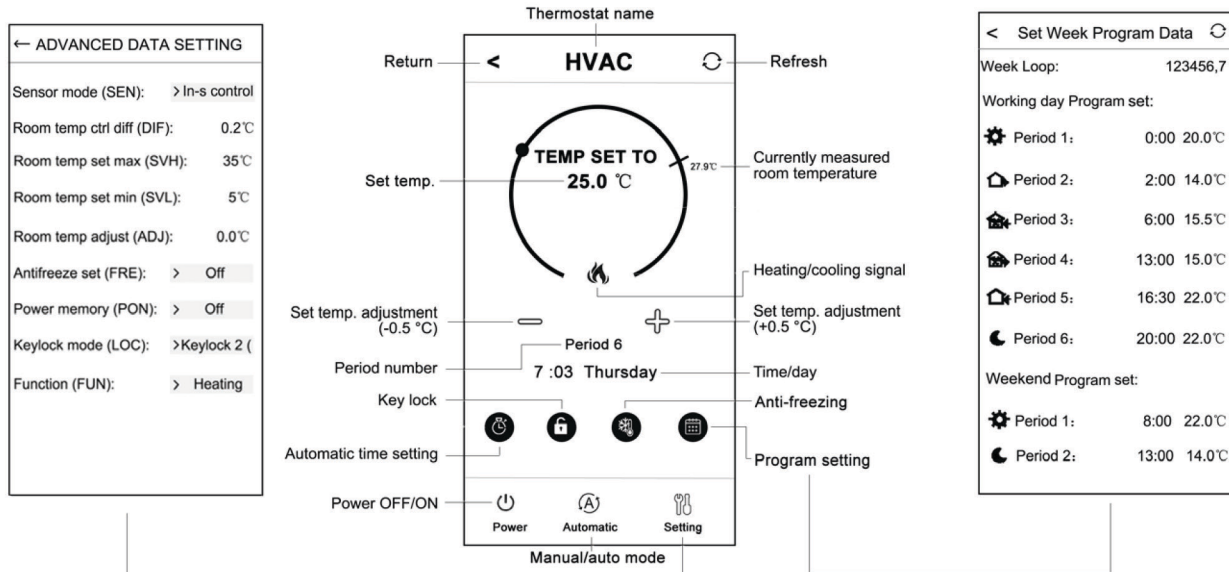

Figure 2.

6. LOCATION OF THE THERMOSTAT AND THE RECEIVER UNIT

It is expedient to install the thermostat in a room used regularly or for a prolonged stay, so that it is located in the direction of natural air movement in the room, but do not expose it to draughts of air or extreme heat effects (e.g. solar radiation, refrigerator or chimney). Its optimal position is at a height of 0.75-1.5 m from the floor level.

The receiver of the **COMPUTHERM E80ORF** thermostat should be installed near the boiler, in a place protected from moisture, dust, chemicals and heat. When selecting the location of the receiver, also take it into account that the propagation of radio waves is caused by large metal objects (eg boilers, buffer tanks, etc.) or metal building structures may be adversely affected. If possible, we recommend to install the receiver at a distance of at least 1-2 m from the boiler and other large metal structures, at a height of 1.5-2 m, to ensure interference-free radio frequency communication. We recommend to check the reliability of the radio frequency connection at the selected location before installing the receiver.

ATTENTION! Do not install the receiver under the boiler cover or in the immediate vicinity of hot pipes, as this may damage the components of the appliance and endanger the wireless (radio frequency) connection. To prevent electric shock, entrust a professional to connect the receiver unit to the boiler.

IMPORTANT WARNING! If the radiator valves in your flat are equipped with thermostat head then set the thermostat head to maximum level in the room where you intend to locate the room thermostat or replace the thermostat head of the radiator valve with manual regulating knob, otherwise the thermostat head may disturb the temperature control in the flat.

7. CONNECTION AND INSTALLATION OF THE THERMOSTATS AND THE RECEIVER UNIT

ATTENTION! Make sure that the **COMPUTHERM E80ORF** thermostat and the apparatus to be controlled are de-energized while putting them into operation. The device should be installed and put into operation by a competent person! If you do not possess the necessary skills and qualifications, please get in touch with an authorized service!

CAUTION! The modification of the device poses a risk of electric shock or breakdown!

ATTENTION! We recommend that you install the heating system that you want to control with the **COMPUTHERM E80ORF** multi-zone thermostat in such a way that the heating liquid can circulate in the closed position of all zone valves in case that one of the circulation pump is switched on. This can be achieved with a permanently open heating circuit or by installing a by-pass valve.

7.1. Putting the thermostat into operation

Connect the front of the thermostat to its holder, then connect the USB-C power cable to the back of the holder. Then connect the other end of the USB cable to the adapter included in the package and connect it to the 230 V mains. (Figure 3)

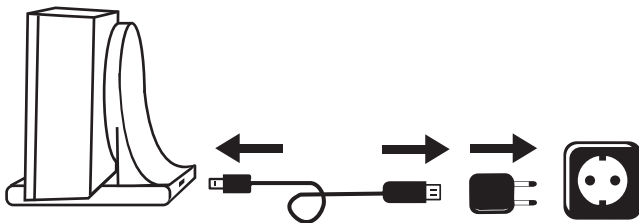

Figure 3.

7.2. Putting the receiver unit into operation

To put the receiver into operation, loosen the screws on the bottom of the product without removing them completely, then separate the front panel of the receiver from the back panel. After that, fasten the back plate with the supplied screws to the wall near the boiler. Under the connectors, printed on the electrical panel, there are inscriptions marking the connection points, which are as follows: **L N 1 2 3 4 5 6 7 8**

 **NO COM NC** 

7.2.1. Connecting the controlled device(es) to the receiver unit

The receiver with changeover output controls the boiler (or air conditioner) via a potential-free relay with connection points: **NO**, **COM** and **NC**. The connection points for the room thermostat of the heating or cooling device to be controlled should be connect the terminal block in the rest open state to the **NO** and **COM** terminals. (figure 4).

In case the device to be controlled does not have a thermostat connection point, the power supply wire of the device to be controlled must be disconnected and connected to the **NO** and **COM** connection points of the thermostat (Figure 5).

ATTENTION! When designing the connections, always take care the load capacity of the receiver and follow the instructions of the manufacturer of the device to be controlled! Leave the wiring to a professional!

The **NO** and **COM** connection points close in response to a heating/cooling command from any thermostat. The voltage appearing at these points depends only on the controlled system, therefore the size of the wire used is determined by the type of controlled device. The length of the cable is irrelevant, you can install the receiver next to the boiler or away from it, but do not install it under the boiler cover.

In addition to controlling (switching on/off) the boiler/air conditioner, the receiver is also suitable for opening/closing the valve(s) of 8 different heating/cooling zones, as well as for controlling a pump. At the connection points of the zone valves, 230 V AC voltage appears on the heating/cooling command of the thermostat belonging to the zone. The zone valves must be connected to points 1, 2, 3, 4, 5, 6, 7 and 8 of the terminal block. A voltage of 230 V AC appears at the connection points of the pump at the heating/cooling command of any thermostat. The pump must be connected to the terminal  point.

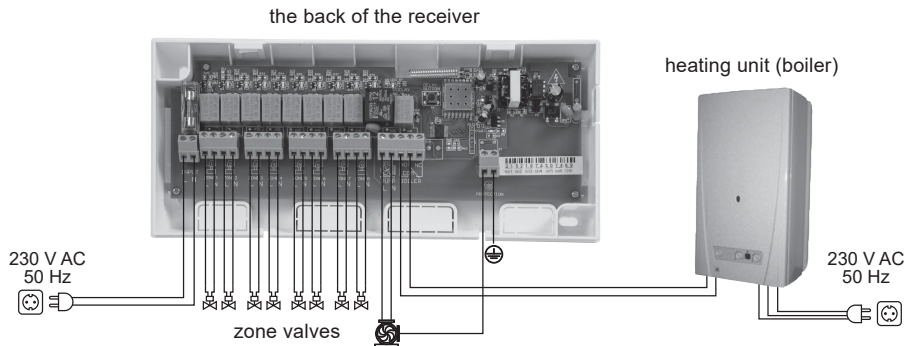

A **COMPUTHERM E80ORF** vevőegység csatlakozóinak méretei max. 2-3 párhuzamosan kapcsolt készülék (zónaszelep, szivattyú, stb.) vezetékeinek fogadására alkalmasak. Ha egy zónakimenethez ennél több készüléket (pl. 4 db zónaszelepet) kíván párhuzamosan csatlakoztatni, akkor azok vezetékeit még a bekötés előtt közösítse és csak a közös vezetéket csatlakoztassa a zónavezérlőhöz.

When using slow-acting electrothermal zone valves, if all zone valves are closed in the default position without heating, it is recommended to delay the start of the boiler in order to protect the boiler pump. You can find more information about the delay of the outputs in **Chapter 11.7**.

















7.2.2. Connecting the receiver unit to the mains

The 230 V power supply should be connected to the terminals marked **N-L** inside the receiver unit with a two-wire cable. This provides power to the receiver, but this voltage does not appear on the output connection points (**NO**, **COM** and **NC**) of the boiler control relay. The neutral wire of the network must be connected to the „**N**” point, while the phase wire must be connected to the „**L**” point. It is not necessary



to pay attention to the phase correctness when connecting the power supply and it is not necessary to connect a ground because the product is double insulated. The grounding point on the electrical panel is not used for grounding the entire receiver, it is only an option for the grounding of the product connected to the receiver to be solved inside the receiver.

7.3. Synchronization of the thermostat and the receiver unit

The two units are synchronized in the factory. The thermostat and its receiver have their own security code, which guarantees the safe operation of the device. If for some reason the thermostat and its receiver unit do not communicate with each other, or if you do not want to use the factory-paired thermostat and receiver together, make the following steps to synchronize the thermostat and the receiver unit:

- Look at the 14 digit identification code inside the receiver, glued to the electrical panel or to the side of the receiver.
- Enable the **“Synchronize with Receiver”** function in the thermostat as described in **Chapter 11**.
- Turn off the thermostat, then touch and hold the  arrow while tapping the  button. Then the  sign appears on the right side of the display and a two digit number appears on the left. This  value must match the first 2 digits of the identification code on the receiver unit. If the displayed number and the first two digit numbers of the receiver identification code do not match, use the   the arrows to change it.
- Press the  button on the thermostat. Then the  sign appears on the right side of the display and a two digit number also appears on the left side. If the displayed number and the third and fourth digits of the receiver identification code do not match, use the   arrows to change it.
- Also set , ,  and  in a similar way as above described.
- After setting the appropriate  értéket is, érintse meg a  value, touch the menu button. Then the  vsign will appear on the right side of the thermostat display, and a two-digit number will appear on

the left side, which is a verification code. If this number does not match with the last two digits of the number sequence on the receiver unit, one of the S_i values has been set incorrectly. In this case, start the alignment again and check the set values.

- If the C_{RF} value displayed on the thermostat matches the last two digits of the number on the receiver, press the  button again.
- The thermostat's display shows the URL text on the right and the S_i number on the left. This function may be used in a future development of the product. Do not change this value, just tap  to complete the synchronization.
- The thermostat synchronizes with the receiver within 1 minute after performing the synchronization steps.

Attention! After a short time when finishing synchronization, the “Synchronize with receiver” function is automatically disabled and remains disabled until it is re-enabled.

The thermostat repeats the on/off commands to the receiver unit every 6 minutes.

8. SETTING UP THE INTERNET CONTROL

8.1. Installing the application

The thermostat can be controlled by both a smartphone and a tablet with the help of free application **COMPUTHERM E Series**. Application **COMPUTHERM E Series** can be downloaded to iOS and Android operating systems.

The applications are accessible through the following link or using a QR code:

https://computherm.info/en/wi-fi_thermostats







Attention! In addition to English, the application is also available in Hungarian and Romanian languages, and is automatically displayed in the language corresponding to the default settings of the phone (in case of default settings are other than these three languages, it is displayed in English.)

8.2. Connecting the thermostat to a Wi-Fi network

To be able to control the device remotely, you need to be connected to the Internet via a Wi-Fi network. The already configured **COMPUTHERM E800RF** can work according to a pre-set program without the need for a permanent Internet connection.

Figyelem! The thermostat can only be connected to a 2.4 GHz Wi-Fi network.

To complete the synchronization, follow these steps:

- On your phone/tablet switch on Wi-Fi connection. Join the **2.4 GHz** Wi-Fi network to be used for the thermostat.
- Activate the positioning (GPS location) feature on your phone.
- Start the **COMPUTHERM E Series** application.
- Give all the requested access to the application in order for it to work properly.
- button on the thermostat.  button on the thermostat.
- Touch and hold the  button for approx. for 10 seconds until the  symbol on the display flashes quickly.
- Now touch the **“Configure”** icon in the right bottom corner in the application.
- On the page that appears, the name of the Wi-Fi network you want to use is displayed (if not, make sure your phone is connected to that Wi-Fi network, that your phone application has all the necessary permissions, and that the GPS location data is turned on). Enter the network password, then tap the **„Connect”** icon.
- The connection has been established successfully between the thermostat and the Wi-Fi network when on the display of the thermostat the  symbol starts to illuminate continuously.

8.3. Connecting the thermostat to the application

- You can search for **COMPUTHERM E40ORF** thermostats connected to the Wi-Fi network concerned by tapping the “**Search**” icon in the left bottom corner (i.e. this requires that the thermostat is connected to the same Wi-Fi network used for the phone).
- On the appearing page “**Search List**” you can choose the thermostat you wish to assign to the installed application. Touching the name of the thermostat concerned, it is assigned to the application and from now on the thermostat can be controlled from anywhere. Following this, on the start screen of the application all assigned thermostats appear, together with currently measured (**PV**) and set (**SV**) temperatures.

8.4. Controlling a thermostat by multiple users



When several users wish to control the same thermostat, after the thermostat has been put into operation the following steps should be carried out to add further users:

- Connect your smartphone/tablet to the Wi-Fi network to which the **COMPUTHERM E40ORF** thermostat has been connected.
- On the apparatus you want to use for controlling download then start application **COMPUTHERM E Series**.
- On the appearing page “**Search List**” you can choose the thermostat you wish to assign to the installed application. Touching the name of the thermostat concerned, it will be assigned to the application, and from now on the thermostat can be controlled from anywhere. Following this, on the start screen of the application all assigned thermostats appear, together with currently measured (**PV**) and set (**SV**) temperatures.

Attention! Alf you want to avoid that other users can add your **COMPUTHERM E40ORF** thermostat to their phone applications, you can disable this operation as described in **Sub-chapter 10.2**.

9. OPERATION OF THE THERMOSTAT

The thermostat controls the device(s) connected to it (e.g. gas boiler, zone valve, pump) on the basis of the temperature measured by itself and currently set, considering the switch sensitivity of the thermostat (± 0.2 °C by factory default). This means that if the thermostat is in heating mode, the temperature is set to 22 °C on the thermostat and then at a switching sensitivity of ± 0.2 °C, then at a temperature below 21.8 °C at the output of the receiver for the given zone or the shared the 230 V AC voltage appears on the pump output. At a temperature above 22.2 °C, the 230 V AC voltage is cut off at the output of the receiver unit belonging to the given zone and at the output of the pump. In cooling mode, the receiver switches exactly the opposite way.

The switched-on status of an output of a given zone is indicated by the lighting of the red LED belonging to the given zone on the receiver, as well as the  or  icon on the device display and in the telephone application according to the selected operating mode.

The boiler and pump control outputs of the device are switched off in the default state (when all thermostats connected to the receiver give the switch-off command). These outputs are turned on when at least one thermostat gives an on command, thereby starting the devices connected to them, and they only turn off when all thermostats send an off signal to the receiver. The switched-on state of these outputs is indicated on the receiver by the lighting of the orange (**PUMP**) and blue (**BOILER**) LEDs belonging to these outputs.

10. BASIC SETTINGS

After the application has been started, **COMPUTHERM E Series** thermostats assigned to the application concerned appear on page “My Thermostat’s”.

10.1. Renaming the thermostat assigned to the application

To modify the factory name, tap and hold the thermostat concerned within the application until a pop-up window with the name of “**Edit Thermostat**” appears. Here you can modify the name of the thermostat within the

application by tapping the “**Modify current thermostat**” icon.

10.2. Disabling further connections of the thermostat assigned to the application

If you want to prevent other users from assigning the thermostat to their phone applications then tap and hold the thermostat concerned within the application until a pop-up window with the name of “**Edit Thermostat**” appears. Tapping the “**Lock current thermostat**” icon, here you can disable matching the application for other users. Until this function is unlocked the thermostat can only be used by users who have already added the device to their application, and new users will not be able to join the device through the Wi-Fi network.





Attention! When a phone/tablet has already been connected to the Wi-Fi network concerned and application **COMPUTHERM E Series** has been opened on it then addition of the thermostat to this phone/tablet cannot be disabled with function “Lock current thermostat” any longer.



10.3. Deleting the thermostat assigned to the application

If you want to delete the assigned thermostat from the application then tap and hold the thermostat concerned within the application until a pop-up window with the name of “**Edit Thermostat**” appears. Here you can delete the thermostat from the application by tapping the “**Delete current thermostat**” icon.

10.4. Setting the day and time



- Using phone application:
To set date and time click on the ⌚ icon in the phone application after the thermostat has been selected. Now the thermostat sets date and time automatically via Internet.
- On the thermostat:
While the thermostat is on, tap the ⌚ button on the thermostat. Then the numbers indicating the hour are flashing on the display. With the help of the ▲▼ buttons set the exact hour then

tap the  button again. Then the numbers indicating the minute are flashing on the display. With the help of the   buttons set the exact minute then tap the button  again. Then one of the numbers 1 2 3 4 5 6 and 7 days of the week, will be flashing.





With the help of the   buttons set the day. By tapping the  button again the thermostat will be reset to its initial state.

10.5. Locking operating buttons

- Using phone application:

To lock operating buttons tap the  icon in the phone application after the thermostat has been selected. Henceforward the device cannot be controlled by the touch buttons on the thermostat until the operating buttons are unlocked. To unlock the operating buttons tap the  icon again in the phone application.

- On the thermostat:

While the thermostat is turned on, tap and hold the  button for long (for approx. 10 seconds) until the  icon appears on the display of the thermostat. Henceforward the device cannot be controlled by the touch buttons on the thermostat until the operating buttons are unlocked. To unlock the operating buttons tap and hold the  icon for long (for approx. 10 seconds) until the  icon disappears on the display of the thermostat.

11. OPERATION-RELATED SETTINGS

For the operation of the thermostat, and to delay the boiler control output on the receiver some functions can be set. Operation-related settings can be performed in the following way:

- Using phone application:

Tap the  icon in the right bottom corner. The settings menu of thermostat, where you can modify the settings, will appear.

- On the thermostat:

- Turn off the device by tapping the  button.

- Tap and hold the ⏸ button and at the same time, touch the ⏻ button for a short time.
- Now the thermostat enters the settings menu: ⚙️ will appear instead of the set temperature.
- Tapping the ↺ button you can switch between the functions to be set.
- A given function can be set by ▲▼ arrows.
- To exit the settings menu and save the settings:
 - switch the appliance off and on again using the ⏻ button, or
 - wait 15 seconds until the thermostat display returns to the main screen, or
 - scroll through the settings by pressing the ↺ button.

The setting options are shown in the table below:

Display	Function	Setting Options	Default Setting	Detailed Description
DIF	Selecting switching sensitivity	$\pm 0.1 - \pm 1.0$ °C	± 0.2 °C	Chapter 11.1.
SVH	Defining maximum settable temperature	5 – 99 °C	35 °C	----
SVL	Defining minimum settable temperature	5 – 99 °C	5 °C	----
ADJ	Calibration of the temperature sensor	-3 – +3 °C	0.0 °C	Chapter 11.2.
FRE	Antifreezing	00: OFF	00	Chapter 11.3.
		01: ON		
PON	Memorizing ON/OFF status in case of a power failure	00: OFF	01	Chapter 11.4.
		01: ON		
LOC	Setting the keylock function	01: only On/Off button works 02: all buttons locked	02	----
FUN	Changing between heating or cooling mode	00: heating 01: cooling	00	Chapter 11.5.
SNP	Synchronization with a receiver unit	00: disable synchronization 01: enable synchronization	00	Chapter 7.3.
FAC	Resetting to factory default	00: Resetting to factory default 08: saving settings	08	Chapter 11.6.
----	Delay of receiver unit outputs	----	turned off	Chapter 11.7.

11.1. Selecting the switching sensitivity (DIF)

It is possible to set the switching sensitivity. By setting this value, you can specify how much the appliance switches the connected device on/off below/above the set temperature.

The lower this value, the more uniform the internal temperature of the room, the greater the comfort will be. The switching sensitivity does not affect the heat loss of the room (building).

In case of higher comfort requirements, the switching sensitivity should be chosen so as to ensure the most constant internal temperature. However, also make sure that the boiler is switched on several times hourly only at low outdoor temperatures (eg -10 °C), as frequent switching off and on will impair the efficiency of the boiler's operation and increase gas consumption.

The switching sensitivity can be set between ± 0.1 °C and ± 1.0 °C (in 0.1 °C increments). Except some special cases, we recommend setting ± 0.1 °C or ± 0.2 °C (factory default setting). See **Chapter 9** for more information on switching sensitivity.

11.2. Calibration of the temperature sensor (ADJ)

The measuring accuracy of the thermometer of the thermostat is ± 0.5 °C. The temperature displayed by the thermostat can be modified in 0.1 °C increments in comparison to the temperature measured by the temperature sensor, but the modification can not exceed ± 3 °C.

11.3. Antifreezing (FRE)

When the antifreezing function of the thermostat is activated, the thermostat will switch on its output, regardless of any other setting, when the temperature measured by the thermostat goes below 5 °C. When the temperature reaches 7 °C, normal operation of the output is restored (according to the set temperature).

11.4. Memorizing ON/OFF status in case of a power failure (PON)

By means of the Memorizing Settings function of the thermostat you can select the mode in which the thermostat continues to operate:

- **00/OFF:** the thermostat turns off and remains turned off until this mode is altered, regardless whether the thermostat was on or off before the power failure.
- **01/ON:** the thermostat returns to the same state in which it was before the power failure (default setting)

11.5. Changing between heating or cooling mode (FUN)

You can easily switch between heating (**00**; factory default) and cooling (**01**) modes.

The connection points **NO** and **COM** of the thermostat's output relay close at a temperatures below the set temperature in heating mode and at temperatures above the set temperature in cooling mode (taking the set switching sensitivity into account).

11.6. Restoring default setting (FAC)

All settings of the thermostat, except for date and time, will be restored to factory setting. To restore factory setting, after selecting *FAC* setting option and tapping the ∇ button several times, switch over the appearing $\overline{00}$ setting to $\overline{00}$. Then tap the ↺ button once to restore factory setting.

If you move on by tapping the ↺ button and leaving the *FAC* value at its default value ($\overline{00}$) then the device will not return to default setting but save the settings and exits the operation-related settings menu.

11.7. Delay of receiver unit outputs

When designing the heating zones - in order to protect the boiler pump - it is advisable to try to leave at least one heating circuit that is not closed off with an isolation valve (e.g. bathroom circuit). If this is not implemented, it is recommended to delay the boiler and pump control output of the receiver in order to prevent a situation in the heating system where the valves of all heating circuits are closed but a pump is switched on.

In the activated state, if none of the zones are switched on, in order to open the valves belonging to the given zone before starting the pump(s) and the boiler, the output of the boiler control **NO-COM** and **the common pump output** of the receiver unit are switched with a 4-minute delay after the activation signal of the first thermostat switch, while the 230 V AC voltage immediately appears on the output belonging to the given zone (e.g.: **Z2**).

The delay is mainly recommended if the zone valves are opened/closed with slow-acting, electro-thermal actuators, because their opening/closing time is approx. 4 minutes. If at least 1 zone is switched on, the

output delay function does not work for the switch-on signal of additional thermostats.

To activate/deactivate the output delay function, press the **DELAY BUTTON** inside the receiver for approx. 3 seconds. For safety reasons, use a non-conductive device to press the button.

The activated status of the output delay function is indicated by the continuously lit purple LED labeled **DELAY** inside the receiver. If the function is not activated (factory default), the LED labeled **DELAY** does not light up.

12. SWITCHING BETWEEN ON AND OFF POSITIONS AND MODES OF THE DEVICE

The thermostat has the following 2 positions:

- **OFF position**
- **ON position**

You can switch between off and on positions in the following way:



- Using phone application: by tapping the  icon.
- On the thermostat: tapping the  button.

When the thermostat is off, the screen of the devices turns off and in the application POWER-OFF lettering replaces measured and set temperatures, and the relay outputs of the device go into off (open) position. When the thermostat is on, the display of the device illuminates continuously. If you touch the touch buttons or modify the settings of the thermostat with the phone application, the light intensity on the thermostat gets higher for approx. 10 seconds then falls back to basic level.

When the thermostat is on, it possesses the following 2 modes of operation:

- Manual mode.
- Programmed auto mode.

You can switch between the modes in the following way:

- Using phone application: by touching  or  icons.
- On the thermostat: touching the  button.

The currently selected mode is indicated as follows:





- In the phone application: manual mode by the  icon and programmed auto mode by the  icon.
- On the thermostat: manual mode by the  icon programmed auto mode by one of the following icons        (according to the current switching scheme) and by the  icon.

The two modes are described in detail in the following sub-chapters.

12.1. Manual mode

In manual mode the thermostat maintains a preset temperature until the next intervention. If the room temperature is lower than that set on the thermostat, the output of the thermostat will switch on. If the room temperature is higher than that set on the thermostat, the output of the thermostat will switch off. The temperature to be maintained by the thermostat can be specified in 0.5 °C steps (the minimum and maximum values of the adjustable range are 5 °C and 99 °C, respectively).

The currently set temperature can be modified in the following way:

- Using phone application:
 - with the   icons
 - moving the slide (groove) on the circular scale,
- On the thermostat: with the   buttons.

12.2. Programmed auto mode

12.2.1. Description of the programmed mode

Programming means setting of switching times and selection of corresponding temperature values. Any temperature set for a switch will remain in effect until the time of the next switch. Switching times can be specified with an accuracy of 1 minute. Within the temperature range (the minimum and maximum values of the adjust-

table range are 5 °C and 99 °C, respectively) specified in the settings a different temperature can be chosen for each switching time, in 0.5 °C increments.

The device can be programmed for a period of one week. In the programmed auto mode the thermostat operates automatically, and cyclically repeats the entered switches every 7 days. The following 3 options are available to program the thermostat:

- **5+2 mode:** setting 6 switches per day for 5 working days and 2 switches per day for 2 days of the weekend
- **6+1 mode:** setting 6 switches per day from Monday till Saturday and 2 switches on Sunday
- **7+0 mode:** setting 6 switches per day for every day of the week

If you do not need all adjustable switches on certain days (e.g. only 4 switches is required on working days), you can eliminate unnecessary switches by setting their time and temperature to the time and temperature of the last switch you want to use.

12.2.2. Description of the steps of programming

• Using phone application:

- a) To enter programming mode touch the  icon. Then the screen for programming appears on the display.
- b) The indication of the currently selected programming mode is located at the top of the screen for programming, beside the legend **Programing mode**. Touching this, you can switch between programming modes as follows:
 - **12345,67:** 5+2 mode
 - **123456,7:** 6+1 mode
 - **1234567:** 7+0 mode
- c) Switches belonging to a given programming mode are below the indication of the programming mode. You can modify data (time, temperature) of switches by tapping the value concerned.

d) To complete programming and return to the screen belonging to the thermostat touch the < icon in the upper left corner.

Programs that were set earlier can be checked at any time by entering the programming mode again.

• **On the thermostat:**

a) To enter programming mode touch the  button for approximately 5 seconds. Then on the display the legend **LOOP** appears in place of the hour, and the indication belonging to the currently selected programming mode replaces the current day.

b) With the Δ / ∇ buttons choose the preferred programming mode as follows:

- for **5+2 mode: 12345**

- for **6+1 mode: 123456**

- for **7+0 mode: 1234567**

Now touch the  button again.

c) Following this, you can specify or modify various switch times and temperatures as follows:

- You can switch between switch times with the  button.

- With the help of  you can switch between data belonging to switch times (temperature, hour value of the time, minute value of the time).

- Values are always set by Δ / ∇ buttons.







After the program of weekdays has been set, you can set the program of the days of the weekend. The day and switch being set are shown by the icon flashing on the display.

d) Programs that were set earlier can be checked at any time by repeating the steps of programming mode.



Attention! In the interest of logical programming ensure that in programming the times of successive switches succeed each other during the course of the day, i.e. you should specify switches in chronological order.

12.2.3. Modifying temperature until the next switch in the program

If the thermostat is in programmed mode, but you want to temporarily change the set temperature until the next program switch, you can do so as follows:

- Using the phone application: using the  cons or moving the slide (groove) on the circular scale, the  icon will appear in the application instead of the  icon.
- On the thermostat: using the  buttons. The thermostat's display will show  and  at the same time.

The set temperature this way will remain in effect until the next program switch. The „Modify temperature until the next switch in the program” mode is marked as follows:

- In the phone application: with the: a  icon
- On the thermostat: with the  and  icons

13. PRACTICAL ADVICES, TACKLING ANY PROBLEMS THAT MAY OCCUR

Problem with the Wi-Fi connection

When the product cannot be connected to a Wi-Fi network or cannot be controlled via the Internet because the connection between the product and the Internet interface is lost and the application indicates that the device is not available, we recommend that to check the list of Frequently Asked Questions (FAQs) collected on our website and follow the steps described there.

Use of the application

The phone/tablet application is under continuous improvement. We propose to update the application to the latest version because user experience is improved continuously and new functions are accessible in the updated versions.

FREQUENTLY ASKED QUESTIONS

When you think that your appliance is operating incorrectly or encounter any problem while the appliance is being used then we recommend that you read Frequently Asked Questions (FAQ) available on our website, where we collected the problems and questions that most frequently occur while our appliances are being used, along with the solutions thereto:

<https://computherm.info/en/faq>



The vast majority of the problems encountered can be solved easily by using the hints available on our website, without seeking professional help. If you have not found a solution to your problem, please pay a visit to our qualified service.

Warning! The manufacturer does not assume responsibility for any direct or indirect damages and loss of income occurring while the appliance is being used.

14. MŰSZAKI ADATOK

- Trademark: **COMPUTHERM**
- Model identifier: **E800RF**
- Temperature control class: **Class I.**
- Contribution to the efficiency of seasonal space heating: **1 %**

Termosztát (adó) műszaki adatai:

- **Temperature measuring range:** 0 °C – 50 °C (0.1 °C increments)
- **Temperature measurement accuracy:** ±0.5 °C
- **Adjustable measuring range:** 5 °C – 99 °C (0.5 °C increments)
- **Switch sensitivity:** ±0.1 °C – ±1.0 °C (0.1 °C increments)
- **Temperature calibration range:** ±3 °C (0.1 °C increments)
- **Supply voltage:** USB-C 5 V DC, 1 A
- **Operating frequency:** RF 433 MHz, Wi-Fi (b/g/n) 2.4 GHz
- **Transmission distance:** approx. 250 m in open terrain
- **Storage temperature:** -5 °C ... +55 °C
- **Operating relative humidity:** 5 % – 95 % without condensation
- **Protection against environmental impacts:** IP30
- **Standby power consumption:** Max. 0.1 W
- **Dimensions:** 130 x 23 x 92 mm with the holder (W x H x D)
- **Weight:** 156 g thermostat + 123 g holder
- **Type of the temperature sensor:** NTC 3950 K 10 kΩ 25 °C

Vevőegység műszaki adatai:

- **Power supply voltage:** 230 V AC, 50 Hz
- **Standby power consumption:** Max. 0.5 W
- **Switchable voltage of the relay that controls the boiler:** Max. 30 V DC / 250 V AC
- **Switchable current of the relay that controls the boiler:** 3 A (1 A inductive load)
- **Voltage and loadability of pump outputs:** 230 V AC, 50 Hz, 10 A (3 A inductive load)
- **Voltage and loadability of zone outputs:** 230 V AC. 50 Hz
- **Loadability capacity of zone outputs:** 3 A (1 A inductive load)
Attention! Make sure that the combined load capacity of the zone outputs and the shared pump output is max. 15 (4) A.
- **Delay time for the switch-on signal of the thermostats:** : 4 minutes
- **Protection against environmental impacts:** IP30
- **Storage temperature:** -5 °C ... +55 °C
- **Operating relative humidity:** 5 % — 95 % without condensation
- **Dimensions:** 240 x 110 x 44 mm (W x H x D)
- **Weight:** 379 g

Attention! Make sure that the combined load capacity of the zone outputs and the shared pump output is max. 15 (4) A.

The total weight of the device is approx. 955 g (2 thermostats + 2 mounting brackets + 1 receiver)

The **COMPUTHERM E800RF** type Wi-Fi thermostat complies with directives RED 2014/53/EU and RoHS 2011/65/EU.



Manufacturer:

QUANTRAX Ltd.

H-6726 Szeged, Fülemlüle u. 34.

Telephone: +36 62 424 133 • Fax: +36 62 424 672

E-mail: iroda@quantrax.hu

Web: www.quantrax.hu • www.computherm.info

Country of origin:

Kína