

Operating instructions

for **COMPUTHERM CPA20-6**
and **CPA25-6**

circulation pumps



1. General informations

The **CPA** low-energy circulation pumps are designed for the circulation of water in one-pipe, two-pipe, radiator-based and underfloor heating systems. The permanent-magnet motor and the modern electronic control of the pump enables the pump to adapt its performance to the current needs of the heating system automatically. Because of this, the energy consumption of these pumps are significantly lower than the consumption of conventional pumps, and they are classified as Energy Efficiency Class A pumps.

CPA pumps can be used for circulating clean, dilute, non-aggressive and non-explosive liquids that do not contain solid particles, fiber or mineral oils. In heating systems the water must comply with the relevant standards requirements for the pump to be usable.

Advantages of the device:

- Automatic, self-regulating mode
- Low energy consumption
- Low noise level

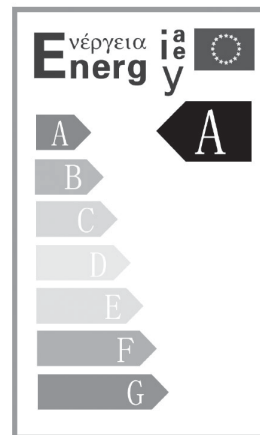

2. Parts of the pump

1. Suction connector
2. Pump housing
3. Pressure connector
4. Engine cover
5. Data plate
6. Venting screw
7. Control panel

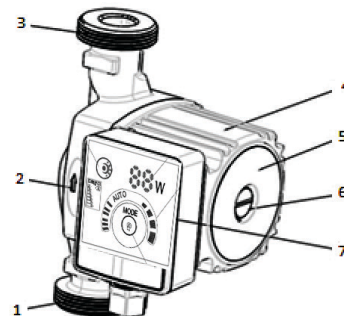

Figure 1

3. Type designation

pump type

CPA20-6

connection size and installation length

20: 1" connection size and 130 mm installation length

25: 1½" connection size and 180 mm installation length

Max. lifting height (m)

4. Important warnings and safety recommendations

- Before using the device, study carefully the device's operating instructions and make sure to follow the instructions carefully.
- This device is designed for indoor use. Do not use in a wet, chemically aggressive or dusty environment, or in a place where it may be splashed by water, or where the ambient temperature may be below 0 °C or above 40 °C.
- The manufacturer is not responsible for any direct or indirect damage or loss of income that may occur during the use of the device.
- Make sure that the **COMPUTHERM CPA20-6/CPA25-6** circulation pump is disconnected from the power supply during the installation!
- The device must be installed, put into operation, and maintained by a competent person and the necessary safety regulations must be followed! If you do not have the necessary knowledge and qualifications, please contact an official service.
- Modifying the device involves the risk of electric shock or malfunction!
- Make sure that the pump housing is not externally insulated, as this can lead to damage to the pump.
- Do not operate the pump empty, without liquid!
- The circulated liquid can be of high pressure or high temperature. Note this when assembling the device to avoid injuries!

5. Installing and commissioning the pump

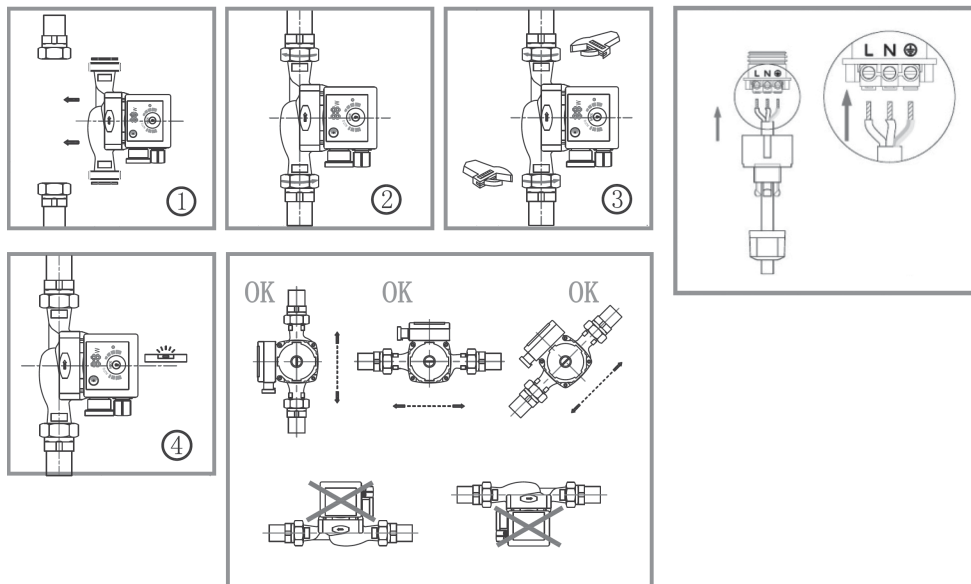

Figure 2

Attention! When starting the pump, make sure that the system is filled with water, vented and the pressure of the suction nozzle reaches the minimum inlet pressure (see **Technical data**).

The pump can empty the remaining air on its own. To do this, switch it to level III for a few minutes

when you turn it on, and the air will leave by itself. During this process, the pump may be louder than usual.

6. Changing the position of the electrical panel

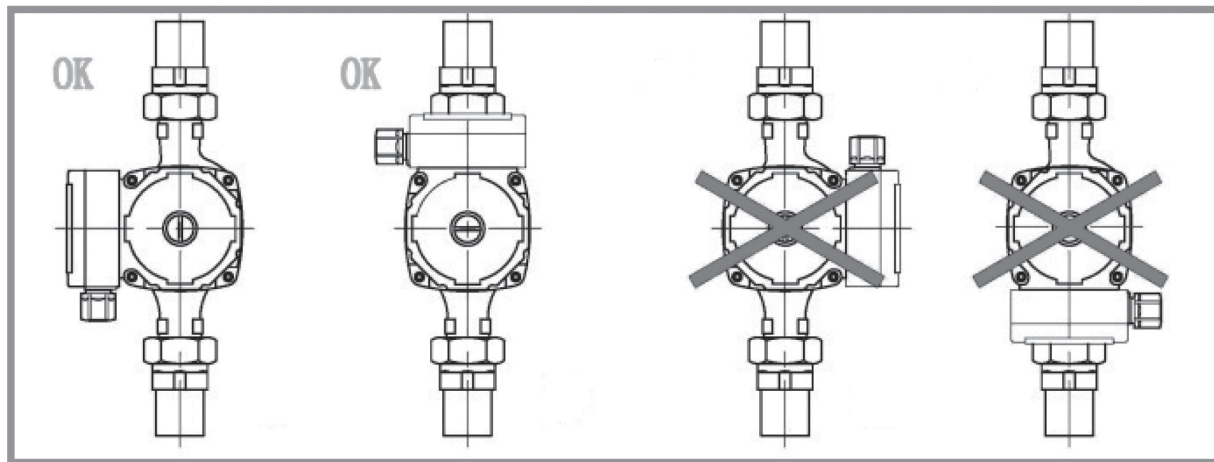

Figure 3

The electrical panel of the pump can be rotated 90 degrees using the following steps:

1. Close the valves on the suction and discharge side and release the pressure.
2. Unscrew and remove the screws on the product.
3. Rotate the pump housing 90 degrees in the desired direction.

4. Screw back the 4 screws securing the electric panel of the pump.
5. Open the valves on the suction and pressure side.

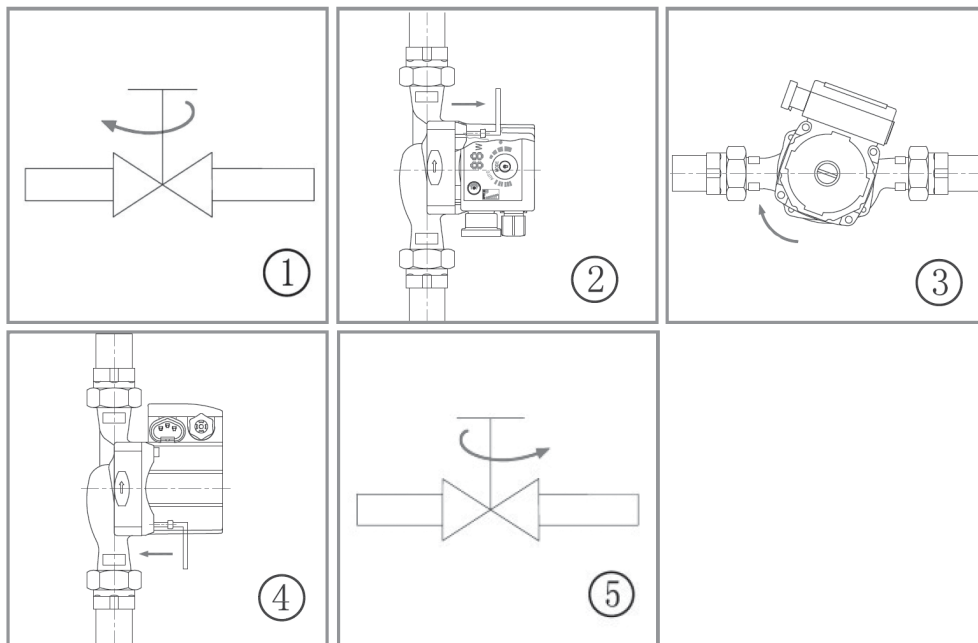

Figure 4

7. Connecting the device to the heating network

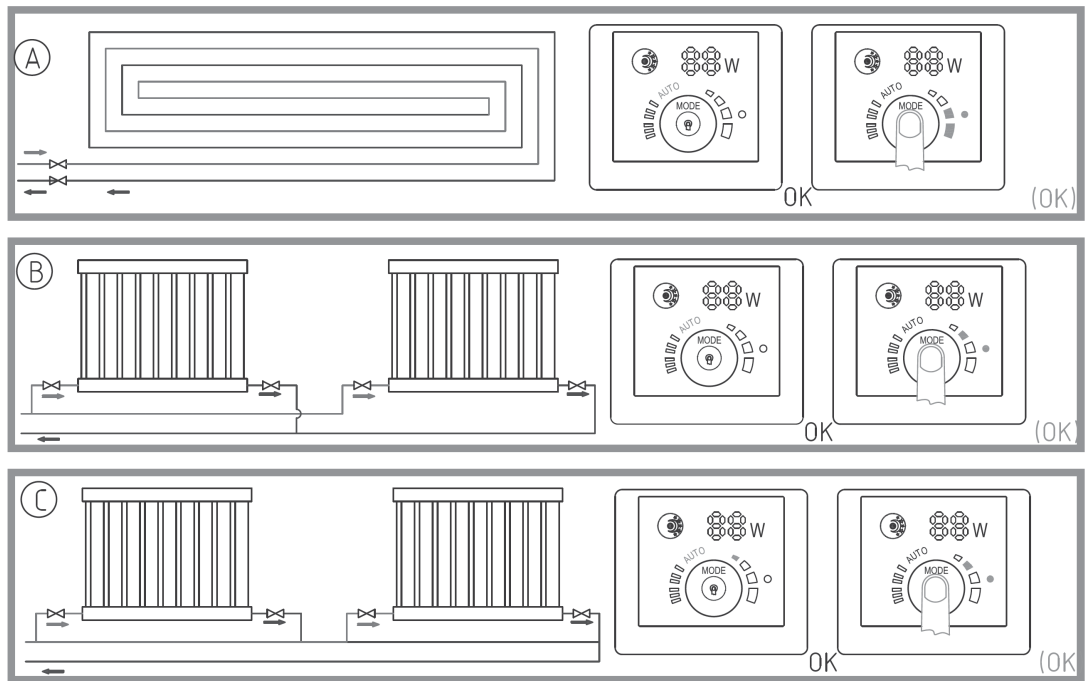

Figure 5

Connecting	Heating system type	Setting pump mode	
		Recommended	Alternative option
A	floor heating	AUTO	HD1, HD2
B	parallel connected heating system	AUTO	BL2
C	series connected heating system	BL1	BL2

8. Control panel

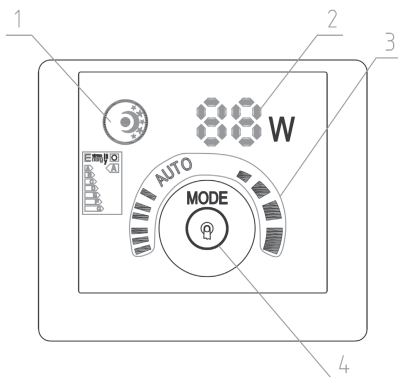

Figure 6

Position	Designation
1	Night mode indicator light. (AUTO)
	Night mode on/off button. (AUTO)
2	Display of current consumption (W).
3	Display of the 8 selectable levels.
4	Button to select the operating mode.

- The segment indicating the currently selected function is always lit on the display panel.
- By pressing the buttons, the pump switches to another operating function.

9. Selectable characteristic curves of the pump and their display

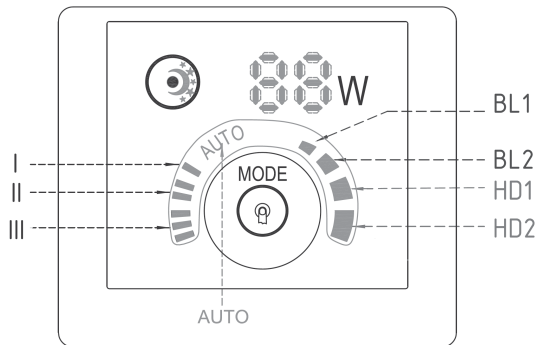

Figure 7

Setting	Pump characteristic	Function
AUTO (default setting)	Automatic curve selection	In the automatic mode, the pump operates at a lower or higher power according to the current water demand.
I	Stage I.	In stage I, the pump operates at a constant speed according to the lowest curve.

II	Stage II.	In the II. stage the pump operates at a constant speed according to the medium curve.
III	Stage III.	In the III. stage, the pump operates at a constant speed according to the highest curve. Quick venting of the pump can be done in III. stage with short-term operation.
BL1	Low proportional-pressure curve	The operating point moves up or down on the low proportional pressure curve according to the heating demand. The delivery height increases when the need increases, decreases when the need decreases.
BL2	High proportional-pressure curve	The operating point moves up or down on the low proportional pressure curve according to the heating demand. The delivery height increases when the need increases, decreases when the need decreases.
HD1	Low Constant-pressure curve	The operating point moves on the low constant pressure curve according to the need. The transport height remains constant regardless of the need.
HD2	High constant-pressure curve	The operating point moves on the low constant pressure curve according to the need. The transport height remains constant regardless of the need.

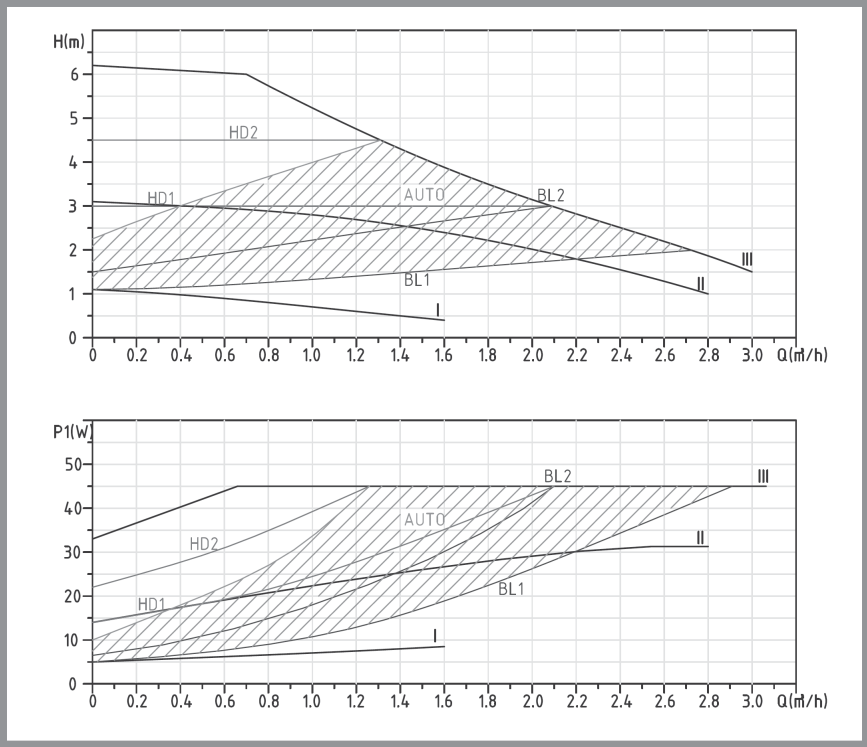

Figure 8

10. Night mode

The **COMPUTHERM CPA20-6** and **CPA25-6** heating circulation pumps can also be operated in Night mode, with which significant energy savings can be achieved. Night mode can be used if the pump is installed in the forward branch of the heating system. When the water temperature sensed by the pump drops by more than 10 °C within 2 hours, the pump automatically switches to the energy-saving mode, by stage I. characteristic curve. When the temperature is rises at least by 10 °C (regardless of the duration), the pump will return to the normal operating mode that was selected before the energy saving mode was activated.

Attention! If the power supply to the pump has been cut off for some time, the Night mode must be reactivated!

Attention! If the pump is installed in the I., II. or III. use it in stage, then the night mode cannot be activated!

To activate Night Mode, press the Night Mode On/Off button on the control panel. Then the button on the control panel will light up until you turn off the function by pressing it again.

11. Displaying errors

In the part of the pump's control panel marked with number 2 (**Figure 2**), instead of the consumption, the error code detected automatically by the pump is displayed. Unplug the device until the error has been eliminated.

Error code	Description
E0	Overvoltage
E1	Low power supply
E2	Overcurrent
E3	Low load level
E2 ⇔ E4 (alternating)	Phase outage

12. Solving possible errors

Error type	Control panel	Possibility sources of error	Troubleshooting
1. The pump not operates.	The control panel does not lights up.	The circuit breaker tripped	Reclosing the circuit breaker.
		A fuse blown.	Replacing the fuse.
		The pump has failed.	Replacing the pump.
	The control panel lights up, but the pump does not operates.	The supply voltage is not correct.	Cheking the supply voltage
The pump is stuck.		Removal of impurities.	
2. Noise in the system.	Everything works as intended.	There is air in the system.	Venting the system.
		The water flow is too high.	Reduction of transport height.
3. The pump is noisy.	Everything works as intended.	There is air in the pump.	Operating the pump, it vents itself over time.
		Low influence pressure.	Increasing influence pressure.
4. Unsatisfactory performance.	Everything works as intended.	Pump performance too short.	Increasing transport height.

13. Mounting sizes

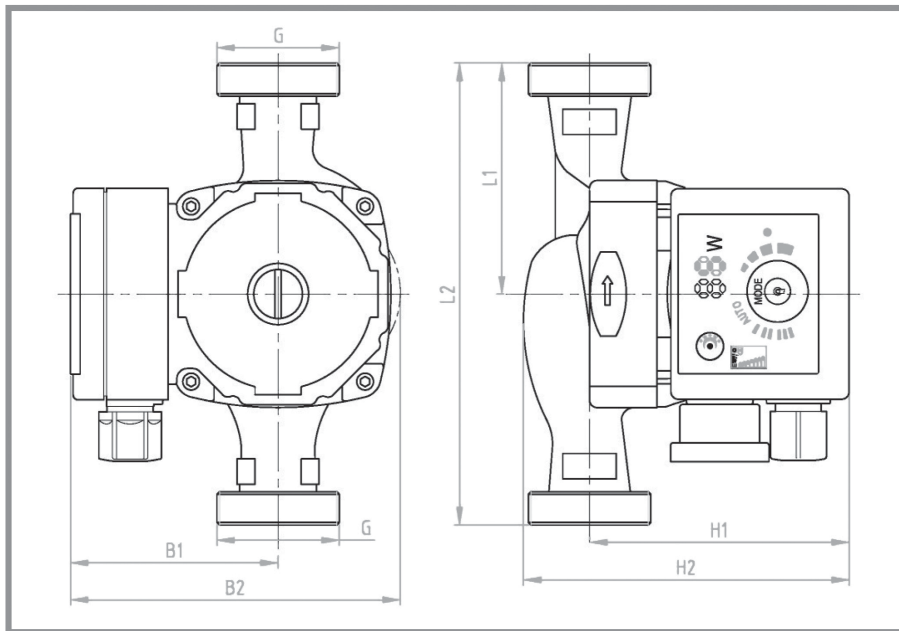

Figure 10

Product name	Measurements (mm)						
	L1	L2	B1	B2	H1	H2	G
CPA20-6	65	130	82	130	103	127	1"
CPA25-6	90	180	82	130	103	130	1 1/2"

Technical data:

Working voltage: 230 V AC; 50/60 Hz
Max. medium temperature: +2 °C – +110 °C
Max. working pressure: 10 bar
Max free air temperature: max. 40 °C
Max. head: 6 m
Max. flow:
 2.8 m³/h (**CPA20-6**), 3.2 m³/h (**CPA25-6**)
Nominal width:
 G 1" (**CPA20-6**); 1 1/2" (**CPA25-6**)
Port to port length:
 130 mm (**CPA20-6**); 180 mm (**CPA25-6**)

Motor performance: 5 – 45 W
Energy label: "A"
Insulation label: H
Type of the motor: induction motor
Material of the motor: cast iron
Material of the runner: PES
Noise level: max. 45 dB
EEl: ≤ 0.23

Suction connector pressure	
Liquid temperature	Minimum inlet pressure
≤ +85 °C	0,05 bar
≤ +90 °C	0,28 bar
≤ +110 °C	1,00 bar

In order to avoid condensation in the junction box and the motor, the recirculated liquid temperature must always be higher than the environment temperature

Environment temperature	Circulated liquid temperature	
	Min	Max
0 °C	2 °C	110 °C
10 °C	10 °C	110 °C
20 °C	20 °C	110 °C
30 °C	30 °C	110 °C
35 °C	35 °C	90 °C
40 °C	40 °C	70 °C

The **COMPUTHERM CPA20-6 / CPA25-6** type pump complies with the requirements of directives EMC 2014/30/EU, LVD 2014/30/EU, and RoHS 2011/65/EU.

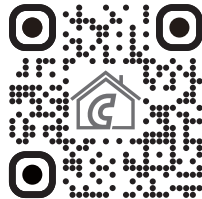

Manufacturer:

Quantrax Ltd.

Fülemüle u. 34., Szeged, H-6726, Hungary

Phone: +36 62 424 133 • Fax: +36 62 424 672

E-mail: iroda@quantrax.hu

Web: www.quantrax.hu • www.computherm.info

Copyright © 2024 Quantrax Ltd. All rights reserved.