

COMPUTHERM B400RF

Wi-fi thermostat



COMPUTHERM B Series

Instruction Manual

Contents

1. A GENERAL DESCRIPTIONS OF THE THERMOSTAT	5
2. IMPORTANT WARNINGS AND SAFETY RECOMMENDATIONS	8
3. MEANING OF THE LED LIGHTS ON THE THERMOSTAT AND THE RECEIVER UNIT	10
4. LOCATION OF THE THERMOSTAT AND THE RECEIVER UNIT	11
5. CONNECTION AND INSTALLATION OF THE THERMOSTAT AND RECEIVER UNIT AND PUTTING IT INTO OPERATION	12
5.1. Installing the thermostat	13
5.2. Installing the receiver unit	13
5.2.1. Connecting the device to be controlled	14
5.2.2. Connecting the receiver unit to the mains supply	15
5.2.3. Synchronization of the thermostat and the receiver unit	15
6. SETTING UP INTERNET CONTROL	16
6.1. Creating a user account	16
6.2. Connecting the thermostat to Wi-Fi network and the user account	17
6.3. Checking the connection of the thermostat to the Wi-Fi network	20
7. OPERATION OF THE INSTALLED THERMOSTAT	20
8. SETTINGS RELATED TO THE USAGE OF THE THERMOSTAT	21

9. OPERATING MODES AND PROGRAMING OF THE THERMOSTAT	27
10. USING ADDITIONAL TEMPERATURE SENSORS	30
10.1. Connecting additional wireless temperature sensor	31
10.2. Connecting additional wired temperature sensor	32
11. USING OF THE THERMOSTAT DISPLAY	33
12. PRACTICAL ADVICE, TACKLING ANY PROBLEMS THAT MAY OCCUR	34
13. PRODUCT INFORMATION AND TECHNICAL DATA	37

1. A GENERAL DESCRIPTIONS OF THE THERMOSTAT

COMPUTHERM B400RF Wi-Fi thermostat is a wireless switching device that can be operated by a smartphone, tablet or computer via Internet, and we especially recommend it for controlling central heating systems but suitable for irrigation systems, garage doors, for remote control of doors and other electrical appliances and programmed also control.

It can be easily connected to any gas boiler having a two-wire thermostat connection point and to any air conditioning apparatus or electrical apparatus, regardless of whether they have a 24 V or 230 V control circuit.

The device consists of two units. One is the thermostat (transmitter unit), the other is the receiver unit that controls the boiler. There is a wireless (radio frequency) connection between the two units, so there is no need to install a wire between the thermostat and the boiler. The two units are synchronized during production. The thermostat and its receiver have their own security code, which guarantees the safe operation of the device. See Chapter 5 and 11 for installation, connection and synchronization of the receiver with the thermostat.

The thermostat does not transmit continuously, but repeats its current switching command every 5 minutes, therefore the heating / cooling control is provided even after a power failure.

The portability of the thermostat offers the following advantages:

- no need to lay a cable, which is especially advantageous when old buildings are being modernized,
- the optimal location of the device can be selected during operation,
- it is also advantageous when you intend to locate the thermostat in different rooms in the course of the day (e.g. in the living room during the day but in the bedroom at night).

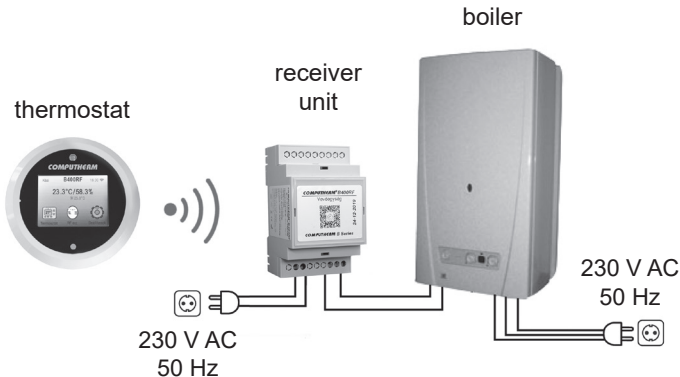

The range of the transmitter built in the thermostat in open area is approx. 250 m. This distance can be significantly reduced inside a building, especially if a metal structure, reinforced concrete, or adobe wall gets in the way of radio waves.

The device can be easily controlled via the Internet and the touch screen, and its operating status (ON / OFF) can be continuously monitored. The device also offers the possibility of automatic control based on temperature and time. The data measured by the humidity and brightness sensor built into the thermostat are displayed on the user interface, which provides to the user additional information about the thermostat's environment. Multiple thermostats, even installed in different locations, can be registered and controlled by using the same user profile.

COMPUHERM B40ORF Wi-Fi thermostats can be used to control:

- gas boilers
- an existing heating/cooling system remotely
- electric water heaters
- solar systems
- certain groups of other electric devices

With the help of the product the heating/cooling system of your flat, house or holiday home can be made controllable from any place and at any time. This

product is especially useful when you do not use your flat or house according to a predefined schedule, you leave your home for an uncertain period of time during the heating season or you intend to use your holiday home during the heating season as well.

The simultaneous use of several **COMPUTHERM** room thermostats and one **COMPUTHERM Q4Z** zone controller provides the possibility for the thermostats to also control a pump or a zone valve in addition to starting the heater or cooler. This way it is easy to divide a heating / cooling system into zones, thanks to which the heating / cooling of each room can be controlled separately, thus greatly increasing comfort. Furthermore, the zoning of the heating / cooling system will greatly contribute to the reduction of energy costs, as due to this only those rooms will be heated / cooled at any time where it is required.

2. IMPORTANT WARNINGS AND SAFETY RECOMMENDATIONS

- Before starting to use the device, please study carefully the instructions for use and follow strictly the instructions therein.
- The thermostat was designed for business or household (not industrial) use, and can be used to control any electric device whose performance

does not exceed 3.6 kW (loadability: max 30 V DC / 250 V AC; 16 A [4 A inductive]).

- Before starting to use the thermostat, make sure that the Wi-Fi network is reliably accessible at the place where you intend to use the apparatus.
- This device has been designed for indoor use. Do not use it in a humid, dusty or chemically aggressive environment.
- This device is a thermostat that can be controlled via a wireless Wi-Fi network. To prevent jamming, keep it away from such electric equipment which may interfere with wireless communications.
- The manufacturer will assume no responsibility for any possible direct or indirect damages or income losses incurring during the use of the device.
- The device will not work without power supply, but the thermostat is able to memorize settings. In case of power failure (outage) it can resume operation without any external intervention after the power supply is restored. If you intend to use the device in an environment where power outages occur frequently, for safety purposes we propose you to control proper operation of the thermostat regularly.

- **Before actually starting to control the device connected to the thermostat, make sure that the device is perfectly functioning when it is controlled by the thermostat and it can be operated reliably.**
- The software of the thermostat and the telephone application is constantly upgraded and updated. For proper operation please check regularly whether there is any accessible software or telephone application update, and always use their latest version! Due to constant updates it is possible that some functions of the device and the applications operate and appear in a way other than described in these instructions for use.

3. MEANING OF THE LED LIGHTS ON THE THERMOSTAT AND THE RECEIVER UNIT

The operating status of the thermostat is indicated by an LED as detailed below:

- When a wireless signal is received, the red LED flashes.
- When a wireless signal is output, the green LED flashes.
- When communicating with a server, the purple LED flashes.

The flashes of the LEDs can be turned off in the touch screen settings.

The operating status of the receiver is indicated by a red and a blue LED as detailed below:

- When wireless signal is received, the blue LED flashes.
- In synchronization mode, the blue LED flashes every 0.5 seconds.
- If the receiver unit is not connected to the thermostat, the blue LED flashes every 15 seconds.
- If the receiver unit output is on, the red LED is lit continuously.

4. LOCATION OF THE THERMOSTAT AND THE RECEIVER UNIT

It is expedient to install the thermostat in a room used regularly or for a prolonged stay, so that it is located in the direction of natural air movement in the room, but do not expose it to draughts of air or extreme heat effects (e.g. solar radiation, refrigerator or chimney). Do not use in wet, chemically aggressive or dusty environment. Its optimal position is at a height of 0.75 - 1.5 m from the floor level. The receiver of the **COMPUTHERM B400RF** thermostat should be installed near the boiler, in a place protected from moisture, dust, chemicals and heat. When selecting the location of the receiver, also take into account that the propagation of radio waves is caused by large metal objects (eg boilers, buffer tanks, etc.) or metal building structures may be adversely affected. If possible, we recommend that you install the receiver at a distance of at least 1-2 m from the boiler and other large metal structures, at a height of 1.5-2 m, to ensure interference-free radio frequency communication. We recommend that you check the reliability

of the radio frequency connection at the selected location before installing the receiver.

ATTENTION! Do not install the receiver unit under the boiler cover or in the immediate vicinity of hot pipes, as this may damage the components of the appliance and endanger the wireless (radio frequency) connection. To avoid electric shock, entrust a professional to connect the receiver to the boiler.

IMPORTANT WARNING! If the radiator valves in your flat are equipped with thermostat head then set the thermostat head to maximum level in the room where you intend to locate the room thermostat or replace the thermostat head of the radiator valve with manual regulating knob, otherwise the thermostat head may disturb the temperature control in the flat.

5. CONNECTION AND INSTALLATION OF THE THERMOSTAT AND RECEIVER UNIT AND PUTTING IT INTO OPERATION

ATTENTION! Make sure that the **COMPUTHERM B40ORF** thermostat and the apparatus to be controlled are de-energized while putting them into operation. The device should be installed and put into operation by a competent person! If you do not possess the necessary skills and qualifications, please get in touch with an authorized service.

Caution! The modification of the device poses a risk of electric shock or breakdown!

5.1. Installing the thermostat

Connect the cable in the product box to the micro USB socket on the back of the thermostat. Then connect the other end of the USB cable to the adapter included in the package and connect it to the 230 V mains (**Figure 1**).



Figure 1.

5.2. Installing the receiver unit

The DIN rail in the thermostat package allows the receiver to be mounted on a wall. To do this, remove the screws and dowels in the plastic bag from the packaging and use them to secure the DIN rail on the wall. Then snap the receiver onto the DIN rail. First the top of the back of the receiver (according to the position of the inscriptions) hook it into the rail and then snap on the bottom as well.

5.2.1. Connecting the device to be controlled

The receiver unit controls the boiler or air conditioner through a potential-free alternating relay with connection points: **NO**, **COM** and **NC**. The connection points for the room thermostat of the heating or cooling device to be controlled should be connected to the **NO** and **COM** connection points of the terminal that are normally open (**Figure. 2**).

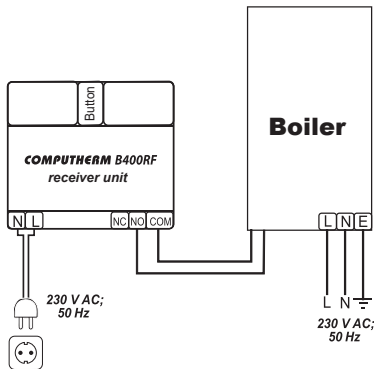

Figure 2.

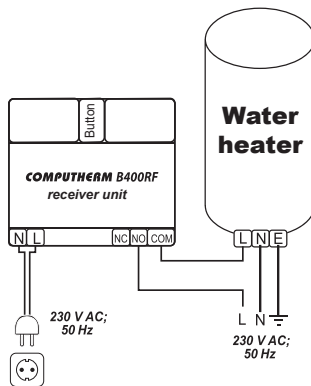

Figure 3.

In case the device to be controlled does not have a thermostat connection point, the power supply wire of the device must be cut off and connected to the **NO** and **COM** connection points of the thermostat (**Figure 3**).

5.2.2. Connecting the receiver unit to the mains supply

The 230 V mains supply should be connected to terminal 2 (**N-L**) on the left side of the receiver with a two-wire cable (**Figure. 2**). It is not necessary to pay attention to the phase correctness when connecting the power supply. It is not necessary to connect a ground wire because the product is double insulated.

5.2.3. Synchronization of the thermostat and the receiver unit

The thermostat and its receiver unit are synchronized in the factory. If the communication between the two units is interrupted, resynchronization can be accomplished as follows:

- Press the button on the side of the receiver unit for 5 seconds. The blue LED inside the product will then flash rapidly.
- Use the thermostat's touch screen to enter the Settings menu and select Pairing. After a short time, the display shows „**Successful pairing!**” text and the synchronization is complete.

6. SETTING UP INTERNET CONTROL

6.1. Creating a user account

The thermostat can also be controlled from a smartphone, tablet (with a free app), a computer (via a web interface) and the touch screen. For smartphones and tablets, the free **COMPUTHERM B Series** app can be downloaded for iOS and Android operating systems. The applications accessible through the following link or using QR code:

https://computherm.info/en/wi-fi_thermostats



A user account must be created to control the thermostat. This can be done in the browser at <https://computhermbseries.com/> and in the phone application. An e-mail address, name and password are required for registration. You can also log in with an existing Facebook or Google account to control the product without registration. After registration, you must log in to the created user account.

6.2. Connecting the thermostat to Wi-Fi network and the user account

To be able to control the device remotely, the thermostat needs to be connected to the Internet via a Wi-Fi network. The already set **COMPUTHERM B400RF** can work according to a pre-set program without the need for a permanent internet connection.

Attention! The thermostat can only be connected to a **2,4 GHz** Wi-Fi network.

There are 3 options to connect the product to a Wi-Fi network and add it to a user account. For each version, use the thermostat's touch screen to enter the Settings menu and then select Wi-Fi. Here you can choose from the following options:

- **SmartConfig:**

If you use the **COMPUTHERM B Series** application, you can have a quick synchronization. Enable the Wi-Fi connection on your smartphone or tablet and connect your device to the **2.4 GHz** Wi-Fi network to which you want to connect the thermostat. Turn on the location service (GPS location data) on your phone and give all the requested permissions to the application in order to work properly. After logging in within the app, touching the “+” icon in the upper right corner will bring up the sync menu. Touching the “**SMART CONFIG**” button will bring up a new page. The name of the Wi-Fi network you want to use appears in the line below the “**SSID**” text and the corresponding password must be typed. Then, by touching the “**Search**” button, the thermostat will connect to the Internet after a short time and will be added to the user account you are currently using.

- **Access Point (Wi-Fi AP):**

If you want to connect the product in the traditional way (eg. by using a web browser), you need to connect it to your Wi-Fi network starting with the word “**Computherm**” created by the thermostat on your smartphone, tablet or laptop. You can also do this on your smartphone and tablet by scanning the QR code that appears on the thermostat display. Then, on the automatically opened page, select the local Wi-Fi network you want to

use and enter the corresponding password. Then click the “**Connect!**” to connect your device to a Wi-Fi network. If the above page does not appear on your device, type the IP address 192.168.10.1 into your browser. The aforementioned connection can be made on the page that appears here. If the connection was successful, the thermostat will display “**Successful connection!**” text.

Then the product must be assigned to a user account. To do this, log in to the previously created account and click on the “+” icon in the upper right corner of the main page. Enter the 10-digit serial number from the bottom of the thermostat in the box below “**Add Device**”. When entering the serial number, you do not have to pay attention to the use of uppercase and lowercase letters. You can then add the device to the user account by clicking the “**SEARCH**” button.

- **Connecting by using the thermostat’s touch screen:**

Select the Wi-Fi network to which you want to connect the thermostat, then use the touch screen to enter its password. The successful connection is indicated by the thermostat display.

The product must then be assigned to a user account. To do this, log in to the previously created account and select the “+” icon in the upper right

corner of the main page. After opening the “**Serial number**” menu under the “**SMART CONFIG**” text, enter the 10-digit serial number from the bottom of the thermostat in the field under “**Add device**”. When entering the serial number, you do not have to pay attention to the use of uppercase and lowercase letters. You can then add the device to the user account by clicking the “**SEARCH**” button.

6.3. Checking the connection of the thermostat to the Wi-Fi network

In the upper right corner of the thermostat display the  icon's color indicates the status of the Wi-Fi connection, as described below:

- **Black:** the thermostat is properly connected to the Wi-Fi network
- **Yellow:** the thermostat is connected to the Wi-Fi network, but there is no connection to the server
- **Red:** the thermostat is not connected to the Wi-Fi network

7. OPERATION OF THE INSTALLED THERMOSTAT

The thermostat controls the device connected to it (e.g. gas boiler or pump) based on the measured temperature and the currently (manually or programmed) set temperature, taking into account the switching sensitivity of the thermostat (factory default ± 0.1 °C). This means that if the thermostat is set to heating mode

and 22 °C, then with a switching sensitivity of ± 0.1 °C the connection points **NO** and **COM** of the output relay are closed below 21.9 °C (heating is turned on) and opened at temperatures above 22.1 °C (heating is turned off). In cooling mode, the relay switches exactly the opposite way.

8. SETTINGS RELATED TO THE USAGE OF THE THERMOSTAT

a) User profile settings

Click the „≡” icon in the upper right corner to select the “**Profile**” menu item. Here you can change the user’s name, phone number and e-mail address. You can also set the language you want to use. After logging in, the user will see the thermostat interface in the selected language. Click the “**SEND**” button to save the changes. You can return to the main menu by clicking the icon in the upper left corner.

The “**Shared devices**” menu item allows you to share the devices attached to the user account with other users. To do this, you need to select the device you want to share, set the share authorization level (limited authorization / full authorization), and enter the email address of the other user account.

You can change the password used to log in by selecting the “**Change password**” menu item by clicking on the „≡” icon in the upper right corner. Click the “**SAVE**”

button to save the changes. You can return to the main menu by clicking the icon in the upper left corner.

You can exit the user account by clicking on the „≡” icon in the upper right corner and clicking on the “Logout” menu item.

A product can only be assigned to one user account at a time. In case two or more separate users want to control the same product, both users must log in to the same user account or share the product with the other user account!

b) Basic settings of the thermostat

On the main screen, click on the  icon next to the thermostat's 10-digit serial number to access the thermostat's default settings. Here it is possible to rename the product. This feature is especially useful when controlling multiple thermostats with a single user account because it makes it easier to differentiate devices. It is also possible to select a time zone valid in the thermostat position. This is important because the thermostat sets the correct time via the Internet according to the selected time zone. You can also enter the position of the thermostat under “Location”, with this, it is easy to distinguish 2 thermostats located in 2 separate properties.

If more than one thermostat is assigned to a user account, switching between the thermostats is possible by clicking the down arrow located left from the thermostat's name. Here you need to select which device you want to use / configure.

c) Operational settings

Click the  icon on the right side of the row below the product name to access the operational settings. Here you can change general and temperature settings.

General Settings

- **Controlling sensor**

If you want to control your heating system based on a wireless temperature sensor or a wired temperature sensor connected to the receiver instead of the built-in temperature sensor, you can select the desired temperature sensor after connecting it in the „**Controlling sensor**” menu.

Attention! Additional temperature sensors are not part of the basic package.

- **Working mode**

By default, the thermostat is in heating mode, according to which its output switches on (**NO-COM**) if the set temperature is higher than the measured temperature, taking into account the switching sensitivity. In the „**Working**

mode” menu, you can switch the thermostat to cooling mode. In this case, the output of the thermostat switches in the opposite way.

- **Temperature accuracy**

You can select the accuracy with which the displayed and adjustable temperature values are displayed in the user interface. When „**0**” is selected, temperature values are displayed in 1 °C increments, and when „**0.0**” is selected, in 0.1 °C increments are displayed.

- **Input calibration**

It is possible to calibrate the temperature measured by the selected control temperature sensor if you think it is not measuring properly. In the drop-down menu, you can select the calibration level from - 9.9 °C to + 9.9 °C. With the selected value, the measured temperature will be modified and the thermostat will continue to operate accordingly.

Main sensor's notification limits

By entering the Min. And Max values, you can set temperatures which are constantly monitored, and if the measured temperature goes below the Min. value or above the Max. value, a warning e-mail or notification is sent.

Temperature sensors

By default, the thermostat has a built-in temperature sensor in the display unit. The name of this temperature sensor is „**Relay**” according to the factory

settings. This can be changed by typing the text in the box under „**Relay**” in the „**Temperature sensors**” menu. If an additional temperature sensor is connected to the product, then not only one but as many temperature sensors are displayed under the „**Temperature sensors**” menu item as the number of connected sensors. The name of each connected temperature sensor can be changed.

Attention! Additional temperature sensors are not part of the basic package.

Temperature ranges

It is possible to set the temperature values related to the operation of the thermostat. The „**Minimal**” and „**Maximal**” temperature values under the „**Temperature ranges**” menu item refer to the temperature values that can be selected during programming and manual mode. Clicking on the number displays a drop-down list from which you can select the desired value. The maximum selectable temperature range is -55 °C to +100 °C. It is recommended to set the minimum and maximum temperatures so that they are wide enough for operation, but not unnecessarily large, as this makes it difficult to set the exact temperature later.

Hysteresis (switching sensitivity)

It is possible to set the lower and upper hysteresis (switching sensitivity). By selecting these values, you can specify how much the appliance switches the

connected appliance on/off below/above the set temperature. The lower these values, the more uniform the internal temperature of the room, the greater the comfort. The switching sensitivity does not affect the heat loss of the room (building). It is possible to set the lower and upper hysteresis separately. In both cases, you can select a range of hysteresis settings, which specifies the values between which you can adjust the hysteresis, and then use the circular slider to select the actual hysteresis value.

In case of higher comfort requirements, the switching sensitivity should be chosen so as to ensure the most constant internal temperature. However, also make sure that the boiler is switched on only several times hourly at low outdoor temperatures (eg $-10\text{ }^{\circ}\text{C}$), as frequent switching off and on will impair the efficiency of the boiler's operation and increase gas consumption. Both the lower and upper hysteresis can be set between $0.0\text{ }^{\circ}\text{C}$ and $74.0\text{ }^{\circ}\text{C}$ (in $0.1\text{ }^{\circ}\text{C}$ increments). Except some special cases, we recommend setting $0.1\text{ }^{\circ}\text{C}$ (factory default setting) or $0.2\text{ }^{\circ}\text{C}$ for both values. See Chapter 7 for more information on switching sensitivity.

9. OPERATING MODES AND PROGRAMING OF THE THERMOSTAT

After logging into the user account, the main page contains the operating settings of the thermostat. Using the drop-down tab in the top row, the control interface is displayed after selecting the thermostat you want to use. At the top of this surface the measured temperature, humidity and brightness are displayed, followed by the menu bar for the thermostat. Below this, the temperature and humidity measured by the additional sensors that may be connected, are displayed as well as the desired temperature and operating mode setting interface.

The thermostat has the following operating modes:

- „**Off**” mode
- „**Manual**” mode
- „**Schedule**” mode
- „**Boost**” mode

You can switch between the operating modes by clicking on the button corresponding to the names. To activate the “**Boost**”, drag the slider below the name.

a) „Off” mode

In this case, the thermostat's output is off until the user switches the device to another mode.

b) „Manual” mode

In this mode, a desired temperature can be set on the slider. The thermostat's output switches on if the measured temperature is lower than the set temperature, it switches off if it is higher than the set temperature.

c) „Schedule” mode

When the “**Schedule**” mode is selected, the thermostat controls the connected device according to a preset program.

Modifying a program using the *COMPUTHERM B Series* application:

To change the thermostat's program, click on the clock icon under the thermostat's name. To change the program for a given day, click on the abbreviation of the day. By default, each day has a switch from 00:00 to 24:00, which is inactive. To activate the switch, click on the right arrow next to the switching time of the selected day and then on the ON/OFF switch. After activation, you can set the temperature for that switch on the slider.

It is possible to create another switch by clicking on the “**Add period**” button for the given day. Up to 8 switches can be set per day. Switches created for one

day are displayed during the selected day. The switching times can be changed by clicking on the switching times. To change the temperature for a particular period, click the right arrow next to the period. Here you can select the desired temperature on the circular slider. You can delete switches by clicking the „“ icon next to the slider. You can go back by pressing the left arrow.

By clicking the copy button below the abbreviations for the days, the set program of the given day can be copied to the previous/next day, so it is not necessary to program the other days separately if you want to set the same program. By clicking on the “**Reset schedule**” button, the entire programming set for the week can be deleted.

Modifying a program using the internet browser:

To change the thermostat's program, click on the clock icon under the thermostat's name. To change the program for a given day, click the bar next on the abbreviation of the day. By default, each day has a switch from 00:00 to 24:00, which is inactive. To activate the switch, click on the bar of selected day and then on the ON/OFF switch. After activation, you can set the temperature for that switch on the slider.

It is possible to create another switch by clicking on the „**Add period**“ button for the given day. This divides the existing connection into two nearly identical parts. Up to 8 switches can be set per day. It is possible to change the switching

time in the day by moving the switching point. To change the temperature for a particular period, click on the temperature displayed on the axis. You can also delete switches in the window that appears by clicking on the „” icon.

By clicking the copy button above or below the abbreviations for the days, the set program of the given day can be copied to the previous / next day, so it is not necessary to program the other days separately if you want to set the same program. By clicking on the „**Reset schedule**” button, the entire programming set for the week can be deleted.

d) „**Boost**” mode

The “**Boost**” mode is accessed from the main screen. Use this function to change the currently selected program. During the setting, you can see how long the function will be active. During the countdown, turn the output ON/OFF according to the temperature set on the circular slider and the measured temperature. When the timer expires, the thermostat returns to the mode it was in before the “**Boost**” mode was turned on.

10. USING ADDITIONAL TEMPERATURE SENSORS

In addition to the built-in temperature sensor, the **COMPUTHERM B40ORF** thermostat is able to receive the temperature measured by an additional wireless temperature sensor and the temperature measured by an additional wired temperature sensor connected to the receiver unit.

Attention! Additional temperature sensors are not part of the basic package.

10.1. Connecting additional wireless temperature sensor

Additional wireless temperature sensor can be connected to the thermostat in 6 easy steps:

1. Unscrew the 4 screws on the back of the temperature sensor and remove the cover.
2. As shown in **Figure 4**, adjust the position of the switch so that both switches are in the bottom position (labeled **1** and **2**).

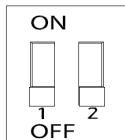

Figure 4.

3. Insert 2 AA alkaline batteries (type LR6) into the temperature sensor.
4. Shortly press the black button inside the temperature sensor.
5. On the thermostat's touchscreen, enter the Settings menu and tap Pairing.

After a short time, the display shows „**Successful pairing!**” caption and alignment is now complete.

6. Replace the cover, then screw in the 4 screws.

10.2. Connecting additional wired temperature sensor

Additional wired temperature sensor can be connected to the thermostat in 6 easy steps:

1. Unplug the receiver unit.
2. Using a flat-headed screwdriver, snap off the cover over the black button by inserting the screwdriver into the slot on top of the cover piece and snapping the cover out.
3. Connect the optional wired temperature sensor to the connector as shown in **Figure 5**.



Figure 5.

4. Using a pair of pliers, break off the two cover parts on the detached cover piece that cover the temperature sensor connector.
5. Replace the cover piece.
6. Plug the receiver to mains.

11. USING OF THE THERMOSTAT DISPLAY

With the help of the thermostat's touch display, you can set the desired temperature, view the measured temperature values and check or change a significant part of the settings without using a smartphone, tablet or laptop.

The following functions are only available using the thermostat's touchscreen:

- Synchronization of the thermostat with the receiver unit or additional wireless temperature sensor
- Touch indicator sound turning On/Off
- Change the display language
- Adjust display brightness/Activate automatic brightness control
- Indicator LED turning On/Off
- Calibrate touch sensor detection
- Restart thermostat
- Factory reset
- Manual firmware update

12. PRACTICAL ADVICE, TACKLING ANY PROBLEMS THAT MAY OCCUR

Problem with the Wi-Fi connection

When the product cannot be connected to a Wi-Fi network or cannot be controlled via the Internet because the connection between the product and the Internet interface is lost and “**Connect**” appears on the interface, we

recommend to check the list of **Frequently Asked Questions** (FAQ) collected on our website and follow the steps described.

Usage of the application

The phone/tablet application is under continuous improvement. We propose to update the application to the latest version because user experience is improved continuously and new functions are accessible in the updated versions.

Usage of the thermostat touch display

The thermostat's firmware is under constant development. If a new version appears, it will be automatically updated on the thermostat if it is connected to a Wi-Fi network. As a result of the update, the thermostat menu may be renewed, new features will appear that were not found in previous versions. If for some reason the firmware does not update automatically, you can also update it manually within the **Thermostat Settings** under **FW Update**.

Synchronization of the thermostat and the receiver unit

The thermostat and the receiver unit are synchronized in the factory. If the communication between the two units is lost, you can re-sync them as described in section **5.2.3**.

FREQUENTLY ASKED QUESTIONS

When you think that your appliance is operating incorrectly or encounter any problem while the appliance is being used then we recommend you to read the Frequently Asked Questions (FAQ) available on our website, where we collected the problems and questions that most frequently occur while our appliances are being used, along with the solutions thereto:

<http://www.computherm.info/en/faq>



The vast majority of the problems encountered can be solved easily by using the hints available on our website, without seeking professional help. If you have not found a solution to your problem, please pay a visit to our qualified service.

Warning! The manufacturer does not assume responsibility for any direct or indirect damages and loss of income occurring while the appliance is being used.

13. PRODUCT INFORMATION AND TECHNICAL DATA

- Trademark: **COMPUTHERM**
- Model identifier: **B400RF**
- Temperature control class: **I. class**
- Contribution to the efficiency of seasonal space heating: **1 %**
- **Temperature measurement range:** -40 °C – +125 °C (in 0,1 °C increments)
- **Temperature measurement accuracy:** ±0,5 °C (in 25 °C)
- **Adjustable temperature range:** -55 °C – +100 °C (in 0,1 °C increments)
- **Temperature calibration range:** ±9.9 (in 0.1 °C increments)
- **Adjustable switching sensitivity:** 0 °C — ±74 °C (in 0,1 °C increments)
- **Humidity measurement accuracy:** ±2 % RH (in 25 °C, 20 to 80 % relative humidity)
- **Temperature and humidity sensor type:** TE HTU21D digital sensor
- **Power supply of thermostat:** micro USB 5 V, 1 A
- **Power supply of receiver unit:** 100-240 V AC; 50/60 Hz
- **Switchable voltage:** max 30 V DC/250 V AC

- **Switchable current:** 16 A (4 A inductive load)
- **Protection against environmental impacts:** IP20
- **Power consumption (thermostat):** Max. 1 W
- **Power consumption (receiver unit):** Max. 1 W
- **Operating frequency:** RF 433 MHz, Wi-Fi (b/g/n) 2,4 GHz
- **RF communication transmission distance:** approx. 250 m in open terrain
- **Storage temperature:** -20 °C - +60 °C
- **Operating humidity:** 5 % — 90 % (without condensation)
- **Weight:** (thermostat + receiver unit): 234 g

The **COMPUTHERM B400RF** type thermostat complies with the requirements of directives RED 2014/53/EU and RoHS 2011/65/EU



Manufacturer:

QUANTRAX Ltd.

Fülemüle u. 34., Szeged, H-6762, Hungary

Phone: +36 62 424 133 • Fax: +36 62 424 672

E-mail: iroda@quantrax.hu

Web: www.quantrax.hu • www.computherm.info

Origin:

EU

